



**Post Office Box 550  
404 East Willow Street • Scottsboro, Alabama 35768  
256.574.1515 • 256.574.1744 • Fax 256.574.1965**

# **STANDARD SANITARY SEWER SPECIFICATIONS**

**REVISION 2023-01**

# TABLE OF CONTENTS

REVISIONS .....	4
Contractor Credentials.....	5
Certificate of Insurance .....	5
Materials.....	5
As-Built Drawings .....	5
Conveyance .....	5
Water/Sewer Project Check List .....	6
DESIGN CRITERIA FOR MANHOLES AND PIPING .....	7
1.1 General .....	7
1.2 Manhole Materials and Construction .....	7
1.3 Flow Channel.....	8
1.4 Bench.....	8
1.5 Manhole Types .....	8
1.6 Manhole Frames and Covers .....	8
1.7 Hydraulic Grade Lines .....	8
1.8 Location of Manholes.....	8
1.9 Connecting to Existing Sewers.....	8
1.10 Pipe Minimum .....	9
1.11 Pipe Depths.....	9
1.12 Force Main Valves .....	9
1.13 Force Main Air & Vacuum Valves.....	9
1.14 Casings .....	9
DESIGN CRITERIA FOR SERVICE LATERALS.....	10
2.1 General .....	10
2.2 Service Lateral Diameters .....	10
2.3 Pipe Materials and Ratings .....	10
2.4 Installation .....	10
2.5 Sewer Service Requirements (Residential and Commercial) .....	11
2.5.1 Residential Sewer.....	11
2.5.2 Commercial Sewer .....	11
2.6 Sewer Service Requirements (R.V. and Mobile Homes) .....	11
EXCAVATING, BACKFILLING AND COMPACTING FOR SANITARY SEWERS .....	12
3.1 Excavating .....	12
3.2 Backfill Requirements .....	12
3.3 Crushed Stone.....	12
CONSTRUCTION REQUIREMENTS.....	13
4.1 Quality Assurance .....	13
4.2 Existing Utilities .....	13
4.3 Protection of Persons and Property .....	13
4.4 Tolerances.....	13
4.5 Shoring and Bracing .....	13
4.6 Pipe Laying.....	14
4.7 Backfill and Fill .....	14
4.7.1 General .....	14
4.7.2 Pipe Bedding .....	15
4.7.3 Backfilling Trenches .....	15
4.8 TESTING METHODS AND SPECIFICATIONS .....	16
4.8.1 General .....	16
4.8.2 Gravity Sewer Testing.....	17
4.8.3 Manhole Testing.....	18
4.8.4 Television Inspection .....	18
4.9 Ditch-line Restoration and Landscaping .....	18

4.10 Hydrostatic Testing of Pressure Sewer Pipe.....	18
FATS, OILS & GREASE (FOG) MANAGEMENT GUIDELINES .....	19
5.1 REQUIREMENTS .....	21
5.2 Certified Hauler/Plumber Program.....	23
5.3 Grease Interceptor (GI) Cleaning/Maintenance Requirements .....	24
5.4 Grease Trap (GT) Cleaning/Maintenance Requirements .....	24
5.5 Additives.....	25
5.6 Enforcement Action.....	25
Fats, Oil, and Grease Interceptor User Compliance Report .....	26
SPECIFICATIONS FOR RESIDENTIAL GRINDER PUMPS .....	27
6.1 General .....	27
6.2 Low Pressure System Design .....	29
6.3 High Pressure System Design.....	30
SMALL CAPACITY DUPLEX SUBMERSIBLE PUMP STATION.....	31
7.1 General Design Criteria .....	31
STANDARD DETAIL DRAWINGS.....	32

## REVISIONS

REVISION DATE	SECTIONS REVISED	REMARKS
<b>May 9, 2023</b>	2.5.11 and 2.5.12 (added) 5.2 – added scanned invoices Standard Detail SD-29b (added)	Revision 2023-1

## **Contractor Credentials**

The Directors of the Waterworks, Sewer and Gas Board of the City of Scottsboro have directed the General Manager to examine the credentials of the contractor, selected by the developer to perform the construction and installation of water/sewer piping, to determine the experience and competency of such contractor. Contractors seeking to install utilities connected to the Board's systems shall provide written proof of satisfactory installations of an equivalent scope of work, as defined in the project proposal, along with names, addresses, and telephone numbers of associated references. In addition, contractors shall provide written documentation of an Alabama Contractor's License with major and specialty classifications for relevant work, Alabama Plumbers & Gas Fitters Examining Board Master Plumber's License, and City of Scottsboro Business License.

## **Certificate of Insurance:**

Any contractor performing water, sewer or gas construction must provide general liability insurance in the minimum amount of \$1,000,000.00 and such policy shall specifically name The Scottsboro Water, Sewer and Gas Board as ADDITIONALLY INSURED. The Certificate of Liability Insurance must be in the possession of The Scottsboro Water, Sewer and Gas Board prior to any inspections and/or other activity requiring the Board's service.

## **Materials:**

Submittals must be approved by the Scottsboro Water, Sewer & Gas Board prior to the start of construction.

## **As-Built Drawings:**

A complete set of As-built drawings is required for all projects. A complete set shall consist of water and/or sanitary sewer lines as constructed, all engineering design specifications (i.e., sewer profiles, pump specifications and details, manholes, valves, fireplug diagrams, etc.) and the engineer's signature and seal. All As-Built drawings must be approved by the SWSG, General Manager prior to any service connection to the lines.

A hardcopy (standard 22" x 34"D-size) and an Auto-Cad file of the As-Built must also be provided to the SWSG upon approval. If As-Built drawings are not in Auto-Cad format, contact Mapping Department.

All As-built drawings should be sent to the following address:

Attention: Mapping Dept.  
Scottsboro Water, Sewer and Gas Board  
P.O. Box 550  
404 East Willow  
Scottsboro, Alabama 35768.

## **Conveyance**

Transfer of ownership of real property to the Scottsboro Waterworks, Sewer and Gas Board will be required upon completion of a development project. Completion shall include satisfactory design, installation, and testing of water/sewer system infrastructure. Property transfer is to include, but not limited to pipes, fire hydrants, manholes, pumping stations, water storage tanks, and all other facilities to be maintained by the Board. These facilities must be conveyed to the Board in the form of a signed "CONVEYANCE", approved and accepted by the Board of Directors. Real estate transfers for sites, such as pumping stations or water storage tanks, must be conveyed to the Board by warranty deed.

# Water/Sewer Project Check List

<b>Project Name:</b>	<b>Owner:</b>
<b>Engineer:</b>	<b>Contractor:</b>

	<b>Date</b>	<b>WSG Approval</b>
* Construction Plans Approved	_____	_____
* Planning Commission Approval	_____	_____
* Contractor Insurance Certificate On File	_____	_____
* As-Built Drawings Complete/Electronic/Paper	_____	_____
* Property/Easements Conveyed to WSG Board	_____	_____
* System Conveyance Approved by WSG Board	_____	_____

## WATER

	<b>Date</b>	<b>WSG Approval</b>
* Approved Material Submittals	_____	_____
* Tie-In to Existing System Complete	_____	_____
* Water Main Installed Per Specs/Plan	_____	_____
* Air Release Valves Operational	_____	_____
* Long Side Services Installed	_____	_____
* Meter Boxes to Grade	_____	_____
* Fire Hydrants to Grade	_____	_____
* Valves Boxes to Grade/Clearly Marked	_____	_____
* Acceptable Hydrostatic Pressure Test	_____	_____
* Acceptable Bacteriological Samples	_____	_____
* ADEM Authorization (if required)	_____	_____

## SEWER

	<b>Date</b>	<b>WSG Approval</b>
* Approved Material Submittals	_____	_____
* Tie-In to Existing System Complete	_____	_____
* Sewer Gravity Main Installed Per Specs/Plan	_____	_____
* Services Installed including ROW Cleanouts	_____	_____
* Manholes to Grade	_____	_____
* Manhole Inverts Complete	_____	_____
* Gravity Lines Cleaned	_____	_____
* TVI Inspection Complete & Approved	_____	_____
* Acceptable Manhole Vacuum Tests	_____	_____
* Acceptable Air Pressure Test on Mainline	_____	_____
* Force Main Installed Per Plan/Specs	_____	_____
* Air Release Valves Operational	_____	_____
* Acceptable Hydrostatic Pressure Test on FM	_____	_____
* Pump Station Start-up Complete by Factory Rep	_____	_____
* Pump Station Property Conveyed to WSG Board	_____	_____
* ADEM Authorization (if required)	_____	_____

## SECTION 1.0

### DESIGN CRITERIA FOR MANHOLES AND PIPING

#### 1.1 General

Note: Scottsboro WSG reserves the right to specify a certain manufacturer's material (which may or may not be described in this document).

In the case of a conflict between the plans and these specifications, these specifications shall govern.

Any sanitary sewer and/or appurtenances that are rehabilitated shall be brought up to conformance with these current specifications.

Connections of anything that collects storm water (i.e. dumpster drains, downspouts, etc.) is **prohibited**.

Manholes shall be installed at the upper end of each line, at all changes in grade, size or alignment, at all sewer intersections and at the appropriate distances. Maximum distances between manholes shall be as shown in Table 1.1 below.

**TABLE 1.1  
LINE LENGTH BETWEEN MANHOLES**

<u>PIPES SIZE</u>	<u>Maximum Length of Pipe Between Manholes</u>
8" – 30"	400'
OVER 30"	400'

Greater spacing may be permitted in larger sewers or in areas where site-specific criteria requires greater lengths with the approval of the Sewer Board. Every effort shall be made to avoid drop inlets.

However, when required, a drop inlet shall be installed in manholes that have an incoming pipe invert elevation 2 feet or more above the out going pipe invert. Channel inverts inside the manhole shall be built up to prevent splashing as shown in the standard detail for drop inlets included in the appendix. The top of manholes are typically set one foot above grade in non-traffic areas to aid in locating and maintenance purposes. However, in certain instances it is desirable to have the manholes flush with the existing ground. Some examples are as follows: for aesthetic reasons, located inside highway right-of-way and located on personal property.

#### 1.2 Manhole Materials and Construction

All standard manholes shall be 4 feet diameter pre-cast concrete and shall meet the requirements of ASTM C-478. Larger diameter manholes will be allowed for larger pipes or as required to accommodate sharp changes in alignment. Manhole sizes for pipes larger than 24 inches shall be verified with manhole manufacturer. The use of Xypex and/or the application of an exterior bituminous waterproof coating on the manholes shall be at the discretion of the sewer board. All pipe-to-manhole connections shall use pre-fabricated flexible connectors such as Kor-N-Seal, or approved equal. New manholes shall have pre-formed holes for pipe installation and existing manholes shall be cored to install pipe and connector. All pipe-to-manhole connections and grade adjustment rings shall be sealed and grouted with non-shrink materials as specified in the sanitary sewer design manual. All lift holes shall be filled with non-shrink grout (See Standard Sanitary Sewer Manhole Details, diagrams SD-1 to SD-7) (See Link-Seal Detail, SD-8).

### **1.3 Flow Channel**

The flow channel shall conform in shape and size to that of the connecting sewers. Minimum drops shall be increased when curved flow channels are required inside manholes. Refer to paragraph 1.7 for additional information.

### **1.4 Bench**

When pipe diameters are less than 48 inches, a bench shall be provided on each side of the flow channel. The bench slope shall be 1 inch per foot. No pipe shall discharge onto the bench surface.

### **1.5 Manhole Types**

Shallow Manhole: defined as any manhole that is 4.5 feet or less in depth, as measured from the invert of the manhole base at its center to the existing ground.

Standard Manhole: defined as any manhole that is greater than 4.5 feet in depth, as measured from the invert of the manhole base at its center to the existing ground.

### **1.6 Manhole Frames and Covers**

Sewers proposed along drains, within potential 100-year flood plains, adjacent to drainage ditches or drainage structures in which there is the potential problem of storm water entering the sanitary sewer shall be designed with the rim elevation above the 100-year flood elevation. The surrounding ground shall be built up around the manhole so that the rim of the manhole is no higher than 4 feet above the ground surface. This will allow easy access to the manhole. In areas where raised manholes are not allowed, such as state roadway right-of-ways, manholes shall be equipped with standard watertight frame and covers as shown in the standard details. All watertight frame and covers shall be bolted to the manhole. All Frame and Covers will be bolted down to the cone section. (see Typical Water-Tight Manhole Detail, SD-19)

### **1.7 Hydraulic Grade Lines**

The hydraulic grade line or energy grade line of flow in a manhole shall always be designed to stay within the crown of the pipe. When the pipe size does not change, or increases by only one pipe size, a minimum elevation drop of 0.2 foot shall be applied to the invert of the outgoing pipe. Calculations shall be performed to insure that the hydraulic grade line stays within the crown of the pipe when there is reason for concern. These calculation checks may be performed by hand calculations or with the aid of computer software.

### **1.8 Location of Manholes**

Manholes located in easements shall be placed outside areas subject to flooding or runoff when possible.

Manholes located in the streets shall be placed a minimum of 5 feet from the edge of the curb or pavement. Every effort shall be made to place the entire manhole frame and cover within the pavement limits. Manholes shall be positioned outside the normal tire path of vehicles.

### **1.9 Connecting to Existing Sewers**

When connecting a new sewer line to an existing manhole, the existing manhole shall be core drilled and flexible connectors, such as Kor-N-Seal or approved equal, installed to connect the pipe.

When connecting new manholes to existing sewers, the new manholes shall be equipped with flexible connectors, such as Kor-N-Seal or approved equal. The new sewer line or manhole shall be connected to the existing sewer line as shown in the standard details.



## 1.10 Pipe Minimum

1. Gravity Sewer PVC Pipe shall be SDR 26
2. Ductile Iron pipe shall be 350 pressure rating
3. Force Main pipe shall be green class 200 PVC (SDR 21) or HDPE DR 11 with green stripe

PVC pipe and fittings must be installed within one year from date of manufacture, as indicated on piping material.

## 1.11 Pipe Depths

PVC pipe for sanitary sewer lines is generally acceptable for depths less than 12 feet. At depths 12 feet and greater, ductile iron pipe is required. For installations in traffic areas or ditches with less than 3 feet of cover, ductile iron pipe or steel casing is required. Transitions from ductile iron pipe to PVC in a line segment are prohibited. The Board reserves the right to require ductile iron pipe for any installation, if in the opinion of the General Manager, conditions warrant the use of ductile iron pipe.

## 1.12 Force Main Valves

All Force Main Line Valves shall be **Dezurik - Plug Valves** or Approved equal.

## 1.13 Force Main Air & Vacuum Valves

All force main air relief valves must be **Crispin Valve** – SA Series, Air & Vacuum Valves or **A.R.I. Combination Valve** – Model D-025.

## 1.14 Casings

Steel casings with a minimum 0.25” wall thickness shall be installed where deemed necessary by the engineer and/or General Manager (see SD-14). Examples are, but not limited to, road crossings, creek crossings, railroad crossings, parking lots, etc. Casings spacers shall be spaced a maximum of one foot from each side of joints and a maximum of 6 feet between spacers (minimum 4 feet). End seals with stainless steel clamps are required on each end of the casing. A 17-lb sacrificial anode (certified packaged Magnesium H-1 Alloy) Grade 1 Falcon Line Products or approved equal shall be cad welded to the steel casing.

## **SECTION 2.0**

### **DESIGN CRITERIA FOR SERVICE LATERALS**

#### **2.1 General**

Service lateral connections shall be with factory- made fittings. Saddle type fittings will not be allowed on new construction. The connection between the service lateral and the sewer main shall be watertight. The service lateral shall not protrude into the sewer main.

#### **2.2 Service Lateral Diameters**

Residential/Commercial service laterals shall not be less than 4 inch in diameter. Industrial service laterals shall be sized according to the quantity of flow produced by the industry; usually 6 inch or 8 inch is required.

#### **2.3 Pipe Materials and Ratings**

Service lateral pipe materials shall be the same as the mainline unless nearby utilities pose problems. Ductile iron pipe service laterals shall be minimum Pressure Class 350. Poly Vinyl Chloride service laterals shall be minimum Schedule 40. (Drain pipe, such as, Foam Core, Cell Core or 40 DWV PVC Pipe is Not Acceptable) Sch. 40 PVC pipe for sanitary sewer service lines is acceptable for depths up to 12 feet. At depths greater than 12 feet, ductile iron pipe is required. For installations in traffic areas, ductile iron pipe is required.

#### **2.4 Installation**

1. Service laterals shall be installed for each lot or property to the property or easement line. (A copy of the recorded sanitary sewer easement must be provided to the WSG for its records prior to the sewer inspection.)
  - a. For existing structures, should the location of the existing sewer service meet grade and other specifications, the new service lateral shall be provided in line with that service.
  - b. For vacant or abandoned property, service laterals shall be installed at the low point of the lot or property. A standard detail for service laterals is included in the appendix.
  
2. An exterior service cleanout shall be installed at the end of the service connection at the edge of the easement, right-of-way, or property line. This cleanout will serve as a location marker as well as a maintenance device. A clean out box shall be installed at the cleanout location. A manhole shall be installed in lieu of a cleanout on all industrial/commercial service lines greater than or equal to 8 inches in diameter.
  - a. Threaded clean-out plugs shall be available at the end of each clean-out.
  - b. Clean-outs located in paved areas, any parking or traffic areas shall have;
    - i. A pre-constructed concrete collar and brass threaded plug at finished level.
    - ii. A clean-out may be recessed below finished level with a brass threaded plug and a traffic rated sewer box installed at finished level.
  - c. Clean-outs located in a sanitary sewer easement shall be recessed below finished level with a threaded plug and a traffic rated sewer box installed at finished level on each clean-out. (see Detail of Clean-out, diagram SD-12)
  - d. Service shall be re-connected with Mission Rubber Co. (non-shear) adjustable repair coupling or approved equal.

## **2.5 Sewer Service Requirements (Residential and Commercial)**

(see Typical Sewer Clean-Out Details, diagrams SD-10, SD-12, SD-12a and SD-12b)

1. Clean-outs shall be at every turn.
2. Turns must be of sufficient radius to accommodate rodding equipment.
3. Clean-outs shall be accessible and capped.
4. Clean out boxes must be installed to finished grade before final inspection and acceptance.
5. The minimum slope on the sewer service shall be 14 inches per 100 feet of pipe (Lesser slope must be approved by WSG).
6. In Paved and Traffic areas ductile iron pipe is required.
7. Each structure must have an unshared connection to the Wastewater Collection System main.
8. Service Tee's must be SDR 26 x Schedule 40 or ductile iron. (Typical SD-12).
9. All connections to Wastewater Collection System shall be made by a certified, licensed plumber by the City of Scottsboro.
10. All piping and connections must be left uncovered to accommodate inspection by the Scottsboro WSG. Pipe manufacturer's markings must be turned as to be clearly visible to accommodate inspection.
11. Except for the connection to the building sanitary sewer at a point not further than 3 feet outside the building, no transitions in piping material are allowed.
12. Connections to the building sanitary sewer at a point not further than 3 feet outside the building, should begin with a transition if required and a cleanout.

### **2.5.1 Residential Sewer**

1. Distance between clean-outs shall be 50-feet.
2. Multiple households will not be allowed.

### **2.5.2 Commercial Sewer**

1. Distance between clean-outs shall be 100-feet.
2. Two-Way clean-outs are required.

## **2.6 Sewer Service Requirements (R.V. and Mobile Homes)**

1. Connections shall be made according to the corresponding detail in these specifications (SD-12a or SD-12b).
2. A lockable, self-closing sewer cap shall be installed on all campsite or mobile home services as shown on the plans.
  - a. Cap shall be GripNLock Sewer Cap as manufactured by Enviro Design Products or approved equal.
  - b. Self-closing sewer cap shall be constructed of material that is UV protected and able to withstand harsh weather conditions.
  - c. Sewer cap shall install on to Schedule 40 PVC pipe with a threaded PVC coupling.
  - d. Sewer cap shall have internal threads when used in R.V. applications.

## **SECTION 3.0**

### **EXCAVATING, BACKFILLING AND COMPACTING FOR SANITARY SEWERS**

#### **3.1 Excavating**

Excavation consists of removal of all material encountered to sub-grade elevations and subsequent disposal or reuse of materials removed. The Contractor shall furnish, place and compact all bedding and backfill materials specified herein or as denoted on the Plans. The materials, equipment, labor, etc. required herein are to be considered as part of the requirements and costs for installing the various pipes, structures and other items that are incidental.

Topsoil shall be removed and stockpiled for later reuse. Subsoil shall be excavated and stockpiled for later reuse as directed in this section. All excavated areas shall be graded and restored to near original contours or to new grading contours as directed on plans after backfilling and compaction is completed.

#### **3.2 Backfill Requirements**

The nature of the materials will govern both their acceptability for backfill and the methods best suited for their placement and compaction in the backfill. No stone or rock fragment larger than 12 inches in greatest dimension shall be placed in the backfill nor shall large masses of backfill materials be dropped into the trench in such a manner as to endanger the pipeline. If necessary, a timber grillage shall be used to break the fall of material dropped from a height of more than 5 feet.

Pieces of bituminous pavement shall be excluded from the backfill unless their use is expressly permitted, in which case they shall be broken up as directed.

#### **3.3 Crushed Stone**

Crushed stone material shall conform to the requirement of the applicable sections of the ALDOT Standard Specifications and shall consist of clean, hard, and durable particles or fragments, free from dirt, vegetation or objectionable materials. Two classes of crushed stone may be referred to in this Section, as follows.

- 1) Class I – ALDOT No. 78 Aggregate.
- 2) Class II- ALDOT No. 410 Aggregate

## **SECTION 4.0**

### **CONSTRUCTION REQUIREMENTS**

#### **4.1 Quality Assurance**

Codes and Standards: Perform excavation work in compliance with applicable requirements of governing authorities having jurisdiction.

#### **4.2 Existing Utilities**

Prior to commencement of work, the Contractor shall locate existing underground utilities in areas of the work. If utilities are to remain in place, provide adequate means of protection during earthwork operations where required. Upon discovery of unknown utility or concealed conditions, affected work shall be discontinued until the Owner is notified.

Alabama One Call 1-800-292-8525 or 811

#### **4.3 Protection of Persons and Property**

Open excavations, occurring as a part of this work, are to be barricaded and posted with warning lights. Operate warning lights as recommended by authorities having jurisdiction.

Protect structures, utilities, sidewalks, pavements, and other facilities from damage caused by settlement, lateral movement, undermining, washout, and other hazards created by earthwork operations.

Protect trees and other features remaining as portion of final landscaping.

Protect benchmarks, existing structures, fences, roads, sidewalks, and other features not designated for demolition.

Contractor shall be responsible to repair any damage to those items not designated for demolition or removal in a manner satisfactory to the owner at no additional cost to the owner.

#### **4.4 Tolerances**

Top surface or sub-grade: Plus or minus three (3) inches.

Top surface of Backfilling: Plus or minus one (1) inch.

#### **4.5 Shoring and Bracing**

The Contractor shall furnish, put in place, and maintain such sheeting, bracing, etc. as may be necessary to support the sides of the excavation and to prevent any movement of earth which could in any way diminish the width of the excavation to less than that necessary for proper construction, or could otherwise injure or delay the work, or endanger adjacent structures. Where unstable material is encountered or where the depth of excavation in earth exceeds 5 feet, the sides of the trench or excavation shall be supported by substantial sheeting, bracing, and shoring, or the sides sloped to the angle of repose. Sloping the sides of the ditch to the angle of repose will not be permitted in streets, roads, narrow rights-of-way or other constricted areas unless otherwise specified. The design and installation of all sheeting, sheet piling, bracing and shoring shall be based on computations of pressure exerted by the materials to be retained under obtaining conditions.

Adequate and proper shoring of all excavations shall be the entire responsibility of the contractor: however, the Owner or Engineer may require the submission of shoring plans for approval prior to the Contractor undertaking any portion of the work.

## 4.6 Pipe Laying

The Contractor shall use a pipe laser to maintain proper grade during installation of the gravity sewer line. The Contractor shall verify pipe invert elevations at sufficient points on the line during installation to correct errors due to laser misalignment, equipment error, etc. All work must conform to the Construction Drawings. The pipe shall be protected during handling against impact shocks and free fall. Care shall be taken to avoid dragging the spigot ring on the ground or allowing it to be damaged by contact with gravel, crushed stone, or other hard objects. After being delivered alongside the trench, the pipe shall be carefully examined for soundness or damage. All pipes shall be new and unused. No piece of pipe or fitting which is known to be defective shall be laid or placed in the lines. If any defective pipe or fitting shall be discovered after the pipe is laid, it shall be removed and replaced with a satisfactory pipe or fitting without additional charge. Before each piece of pipe is lowered into the trench, it shall be thoroughly cleaned out. Each piece of pipe shall be lowered separately unless the Engineer gives special permission otherwise. In case a length of pipe is cut to fit in a line, it shall be so cut as to leave a smooth end at right angles to the longitudinal axis of the pipe. The bell and spigot of the joint shall be cleaned of dirt and foreign matter immediately prior to joining. The contact surfaces shall be coated with a lubricant, primer or adhesive recommended by the pipe manufacturer, and pushed together until the joint snaps distinctly in place. The pushing together of the pipe may be done by hand or by the use of a bar. All pipes shall be laid straight between changes in alignment and at uniform grade between changes in grade. When jointed in the trench the pipe shall form a true and smooth line. Trenches shall be kept dry during pipe laying. Before pipe laying is started, all water that may have collected in the trench shall be removed. All pipes shall be laid starting at the lowest point and installed so that the spigot ends point in the flow. When pipe installation stops for any reason, the exposed end shall be closed with a plywood plug fitted into the bell end, so as to protect it from intrusion of any foreign material. The Contractor shall take all precautions to prevent intrusion of any foreign material into the pipe system. Precautions shall also be taken to prevent flotation of pipe caused by flooding of the trench from surface water or ground water.

## 4.7 Backfill and Fill

### 4.7.1 General

1. No pipe shall be covered until inspected and approved by the WSG.
2. With the exception of the organic and inorganic debris, and topsoil, the on-site soil removed from the excavations can be used as non-structural/non-low permeability fill or vegetative backfill material provided the moisture content of the soil is within acceptable limits.
3. Place acceptable backfill materials in maximum 6 inch to 8-inch lifts (loose thickness) to required sub-grade elevations, for each area classification listed below.
  - a. In excavations, use satisfactory excavated or borrowed material.
  - b. Under slabs, use drainage fill material for a minimum depth of 6 inches. Below drainage fill use satisfactory excavated or borrow material
4. Backfill excavations as promptly as work permits, but not until completion of the following:
  - a. Acceptance of construction below finish grade.
  - b. Recording locations of underground utilities.
  - c. Removal of concrete formwork.
  - d. Removal of shoring and bracing, and backfilling of voids with satisfactory materials. Cut off temporary sheet piling driven below bottom of structures and remove in manner to prevent settlement of the structure or utilities, or leave in place if required.
  - e. Removal of trash and debris.
5. As soon as practicable after the pipes have been laid and the joints have acquired a suitable degree of hardness, if applicable, or the structures have been built and are structurally adequate to support the loads, including construction loads to which they will be subjected, the backfilling shall be started and thereafter it shall proceed until its completion.
6. The Contractor shall dispose of excavated materials from trenches, in excess of quantity required for trench backfill. It shall be the responsibility of the Contractor to obtain location or permits for its disposal, unless specific waste areas have been designated on the Plans or noted in the Design Specifications.

7. The Contractor shall protect all sewer, gas, electric, telephone, water, and drain pipes or conduits from damage while pipelines are being constructed and backfilled, and from danger due to settlement of trench backfill.
8. On completion of the Work, all backfill shall be dressed; holes filled; and surplus material hauled away.

#### **4.7.2 Pipe Bedding**

1. All pipes shall be laid on a bed of granular material except when a concrete encasement situation occurs. All pipe bedding material shall be class I and shall be placed to a depth of 6 inches in an earth trench and 12 inches in a rock trench. The Contractor will not be permitted to use dense graded aggregate material for pipe bedding.
2. Pipe bedding shall be graded to provide for a uniform and continuous support beneath the pipe at all points.
3. After each pipe has been brought to grade, aligned, and placed in final position Class I material shall be deposited and densified under pipe haunches and to a minimum of no less than 6 inches above top of pipe, to prevent lateral displacement and hold the pipe in proper position during subsequent pipe jointing, bedding and backfilling operations.
4. In wet, yielding and mucky locations where pipe is in danger of sinking below grade or floating out of grade or line, or where backfill materials are of such a fluid nature that such movements of pipe might take place during the placing of the backfill, the pipe must be weighted or secured permanently in place by such means as will prove effective.
5. Where an unstable (i.e., water, mud, etc.) trench bottom is encountered, stabilization of the trench bottom is required. This is to be accomplished by undercutting the trench depth and replacing to grade with a foundation of crushed stone aggregate. The depth of the foundation is dependent upon the severity of the trench bottom. The size of stone aggregate used in the foundation will be determined by the condition of the unstable material. Once the trench bottom has been stabilized, the required ALDOT # 78 crushed stone aggregate bedding material can be placed. No additional compensation for Crushed Stone for pipe foundation will be made.
6. No pipe shall be laid on solid or blasted rock.
7. Pipe bedding and trench stabilization as required in Paragraphs a-f of this article are not considered separate pay items.

#### **4.7.3 Backfilling Trenches**

1. Initial Backfill
  - a. Zone around pipe: The zone around the pipe shall be backfilled with the materials and to the limits indicated on the standard details. Uneven places in the backfill shall be leveled by hand.
  - b. Material used, whether earth or Class I, in the initial backfilling is not a separate pay item.
  - c. In areas where large quantities of rock are excavated and the available excavated earth in the immediate vicinity is insufficient for placing the required amount of backfill over the top of the pipe as set forth in Paragraph 1, the contractor shall either haul in earth or order Class I material for backfilling over the pipe. Neither the hauling nor placement of earth nor the ordering and placement of Class I material to fulfill the backfill requirements set forth herein is considered a separate pay item.
  - d. Packing of crushed stone between joints shall be uniform and progress as the pipe laying progresses. This is in order to avoid danger of misalignment from slides, flooding or other causes.

## 2. Final Backfill:

- a. There are two cases where the method of final backfilling varies. The various cases and their trench situations are as follows:
  - i. Case I- Areas not subject to vehicular traffic.
  - ii. Case II- Paved areas including streets, drives and walks where horizontal borings are not specified.
    - In all cases, walking or working on the completed pipelines, except as may be necessary in backfilling, will not be permitted until the trench has been backfilled to a point six (6) inches above the top of the pipe. The method of final backfilling for each of the above cases is as follows:
- b. Case I – The trench shall be backfilled from a point 6 inches above the top of the pipe or as shown on the plans to a point 8 inches below the surface of the ground with earth material free from large rock (over one-half cubic foot in volume), acceptable to the WSG. The remainder of the trench shall be backfilled with earth material reasonably free of any rocks.
- c. Case II - the trench shall be backfilled from a point 6 inches above the top of the pipe to the existing pavement surface with Class II material.
- d. Class II materials will be required in roadways from top of the Class I material to the bottom of the asphalt. (see Typical Trench Detail for Pipe in Traffic Areas, diagram SD-13)
- e. For temporary measures the Class II material may be brought up to the existing pavement surface. A slight mound may be left if, in the opinion of the Owner, the public would not be inconvenienced. Extreme care shall be exercised to prevent damage to the pipe during the backfilling operation.
  - i. Care shall be taken that the material close to the bank, as well as in all other portions of the trench, is thoroughly compacted. When the trench width and the depth to which backfill has been placed are sufficient to make it feasible and it can be done effectively without damage to the pipe, backfill may, on approval, be compacted by the use of suitable rollers, tractors, or similar powered equipment. If necessary to ensure proper compaction by tamping (or rolling) the material shall first be wet by sprinkling. However, no compaction by tamping (or rolling) shall be done when the material is too wet either from rain or too great an application of water to be compacted properly; at such times, the work shall be suspended until the previously placed and new materials have dried out sufficiently to permit proper compacting, or such other precautions shall be taken as may be necessary to obtain proper compaction.

## **4.8 TESTING METHODS AND SPECIFICATIONS**

### **4.8.1 General**

Upon completion of all or part of a sanitary sewer line, the Contractor will be required to test said sewer for acceptability. The Contractor shall provide all necessary water, equipment, and instrumentation for flushing and testing. Source and quality of water, test procedures, and disposal of water shall all be approved by the WSG. If test water is required from the WSG potable water system, the WSG will furnish, free of charge, sufficient water to fill the new sewers two (2) times, after which additional water will be available at the WSG standard rates. The method(s) of testing shall be as specified herein. All tests shall be conducted in the presence of the WSG representative, and preliminary test not observed by the WSG representative will not be accepted. The WSG representative shall be notified at least 24 hours before any work is to be inspected or tested. The WSG representative is available to witness test from 8:00 a.m. to 3:00 p.m., Monday through Friday. If the developer/contractor wishes to conduct testing outside these hours, they shall contact the General Manager concerning charges which will be levied for the WSG representative to be available for witnessing the test, as required. All defective sewer lines shall be repaired, or replaced, and retested until acceptable by the WSG. Repairs shall be made to the standard of quality specified for the entire system.



Sections of the system may be tested separately. However, any defect, which may develop in a section previously tested and accepted, shall be promptly corrected and retested until acceptable by the board. All piping systems shall be tested in accordance with these test methods. Any test required by local plumbing codes or building authorities shall also be conducted. Testing of sewer lines shall include internal television inspection as called for in 4.8.4.

#### 4.8.2 Gravity Sewer Testing

Prior to any testing, all lines shall be cleaned of debris and flushed clean with water as necessary. Debris and flush water shall be caught and removed from the line and shall not be allowed into existing live sanitary sewers. Before sewers are placed into service, the WSG representative shall inspect the sewers for line and grade. All sewer lines shall be air tested in accordance with ASTM C828 as follows:

The sewer lines to be tested shall be tested between manholes. The line shall be sealed at each end. The seal at one end shall have an orifice through which to pass air into the pipe. An air supply shall be connected to the orifice. The air supply line will contain an on/off valve and a pressure gauge with a range from 0 to 10 psi. The gauge shall have minimum divisions of 0.10 psi and shall have an accuracy of +/-0.04 psi.

The pipeline being tested shall be pressurized to 4 psig. The line will be allowed to stabilize between 4 psig and 3.5 psig for a period of no less than 5 minutes. If necessary, air should be added to the line to maintain pressure above 3.5 psig. After the stabilization period, the valve shall be closed. When the line pressure drops to 3.5 psig, timing with a stopwatch should begin. The stopwatch shall run until the pressure drops to 2.5 psig. Then the stopwatch shall be stopped and the time lapse compared with the allowable time lapse in the table below for the pipe size and leakage allowance specified by the WSG.

If the time lapse is greater than that specified, the section being tested shall have passed, and the tests may be discontinued. If the time lapse is less than that specified, the line has not passed the test and the contractor will be required to prepare the line for retesting.

#### Air Leakage Chart

Size of Pipe (inches)	Minutes Seconds Per 100ft
4	1:00
6	1:00
8	1:30
10	2:00
12	2:30
18	3:00
21	3:30
24	4:00
27	4:30
30	5:00
36	6:00

If the pipeline to be tested is beneath the groundwater level, the test pressure shall be increased 0.433 psi for each foot the groundwater level is above the invert of the pipe. Deflection tests of pipe may be required. Tests, as well as tolerances, shall be in accordance with the manufacturer's recommendations or as directed by the WSG, and shall be conducted in the presence of the WSG representative. An acceptable method of testing the deflection would be that the pipe shall pass a vertical floating pin-type go/no-go mandrel (or effective equivalent) sized to 95% of the pipe diameter of the actual pipe used with the pipe placed and covered. The appropriate allowable deflection of the flexible pipe when installed (must be less than 5%) may be calculated using the pipe stiffness formula in ASTM D2321. Deflection test shall be performed not less than 24 hours after backfilling.

### 4.8.3 Manhole Testing

All manholes shall be tested by the following method:

(1) Manhole Vacuum Test. The test shall be conducted by the contractor in coordination with and at the direction of the WSG representative. The manhole shall be tested, after assembly, as follows: All pipe opening shall be sealed by installing suitable plugs that completely isolate the manhole structure; any other openings, such as lifting holes, shall be permanently sealed. A Flat Plat vacuum system and suitable vacuum pump shall be connected to the manhole and a vacuum of 10" Hg drawn. The pump shall then be isolated from the manhole by a valve, and the test period begun. The test shall be successful if the vacuum remains at 9" of Hg or greater according to the following table:

<b>Manhole Diameter</b>	<b>Time, minimum (sec)</b>
48"	60
60"	75
72"	90

All manholes which fail the test or that have visible leaks, even if they pass the test, shall be repaired or replaced at the expense of the contractor until the manholes pass the test, to the complete satisfaction of the WSG. Manholes that have any visible leaks will not be accepted.

### 4.8.4 Television Inspection

The WSG will do T.V.I inspections and the Contractor is responsible for all repairs identified by the T.V.I. inspection.

### 4.9 Ditch-line Restoration and Landscaping

All property located out of the road, either private, within construction easement or public right-of- way, shall be restored to as good or better condition prior to completion date.

### 4.10 Hydrostatic Testing of Pressure Sewer Pipe

1. Following installation of pressure sewer pipe, partially after backfilling, and the necessary concrete thrust blocks constructed, the pipe shall be subjected to a hydrostatic pressure of 100 PSI for a minimum period of two hours. The entire duration of the test shall be recorded on an 8" (minimum) paper chart recorder.
2. The pipe shall be slowly filled with water and the specified test pressure, measured at the point of lowest elevation, shall be applied by means of a pump connected to the pipe. The pump, pipe connection, gauges, meters and other apparatus required for the test shall be furnished and installed by the Contractor.
3. Before applying the specified test pressure, all air shall be expelled from the pipe. To accomplish this, taps shall be made, if necessary, at points of highest elevation and afterward tightly plugged.
4. No leakage is allowed.

## Section 5.0

### FATS, OILS & GREASE (FOG) MANAGEMENT GUIDELINES

Adopted: July 21, 2009

#### Scope & Purpose:

The purpose of these guidelines is to ensure compliance with the Scottsboro Waterworks, Sewer and Gas Board's (WSG) ***FOG Management Policy***. The accumulation of fats, oil and grease (FOG) within the collection system (sewer lines and pump stations) and treatment works can result in a decreased carrying capacity of sewers due to congealed, cooled grease which coats the inside of the sewer pipes. Once a pipe becomes constricted, the potential for a collection system blockage increases. Collection system blockages may cause sanitary sewer overflows (SSO). SSO's potentially degrade the quality of local receiving waters. FOG blockages may also cause sewer back-ups into homes and businesses. The intent of this policy is to prevent collection system blockages, obstructions, and overflows due to the contribution and accumulation of FOG from Food Service Establishments (FSE), commercial facilities, and industrial facilities. This policy applies to all new construction, tenant improvements, remodels, and existing systems that are in need of upgrading.

#### **DEFINITIONS**

Additives: Include but are not limited to products that contain solvents, emulsifiers, surfactants, caustics, acids, enzymes and bacteria.

Exemption: A release from the requirement to install grease control equipment (GCE).

Extensive Remodeling: Modifications made to an existing FSE sufficient to require issuance of a building permit, or the temporary closure of the FSE for building renovation.

Fats, Oils, & Grease (FOG): Organic polar compounds derived from animal and/or plant sources. FOG may be referred to as grease or greases in this section.

Food Service Establishment (FSE): Any establishment, business, facility or user engaged in preparing, serving or making food available for consumption. Single-family residences are not an FSE.

FSE's will be classified as follows:

Class 1: Day Care Facilities, Deli, Ice Cream shops, Coffee Shops, Beverage Bars, Mobile Food Vendors engaged in the sale of cold-cut and micro waved sandwiches/subs with no frying or grilling on site, as defined by North American Industry Classification System (NAICS) 722213.

Class 2: Limited-Service Restaurants - (i.e. Fast Food Facilities) as defined by NAICS 722211 and Caterers as defined by NAICS 722320.

Class 3: Full Service Restaurants - as defined by NAICS 722110.

Class 4: Buffet and Cafeteria Facilities - as defined by NAICS 722212.

Class 5: Institutions (i.e. Schools, Hospitals, Prisons, etc) - as defined by NAICS 722310.

Garbage Disposal: A kitchen appliance designed to grind food particles to a small enough size to dispose to a sink drain.

Grease (Brown): Fats, oils and grease that are discharged to the grease control equipment, or are from kitchen or food prep wastewater.

Grease (Yellow): Fats, oils and grease that has not been in contact or contaminated from other sources (water, wastewater, solid waste, etc) and can be recycled.

Grease Control Equipment (GCE): Devices for separating and retaining FSE wastewater FOG prior to entering the sewer system. The GCE is constructed to separate and trap or hold fats, oils and grease substances from entering the sewer system. GCE should only receive kitchen wastewater. Devices include grease interceptors (normally located outdoors), grease traps (normally located indoors), or other devices approved by WSG.

Grease Interceptor (GI): GCE identified as a large multi-compartment tank, usually 1,000 gallon to 2,000-gallon capacity with proper inlet and outlet T's, and other necessary components, that provides FOG control for a FSE. No sanitary wastewater (black water) line should be connected to the grease interceptor. Grease interceptors will be located outside the FSE.

Grease Trap (GT): GCE identified as an under-the-sink trap, small container with baffles, or a floor trap. The minimum size requirement shall be the equivalent of a 25-gallon per minute/50 pound capacity trap. Grease traps shall have air relief bypass, flow control restrictor, and a vent pipe. No dishwasher or sanitary wastewater (black water) line shall be allowed to be connected to an under-the-sink or floor grease trap.

Grease Recycle Container: A container used for the storage of yellow grease.

Licensed Waste Hauler/Plumber: individuals or entities that are licensed by the Alabama On-site Wastewater Board

Multi-Unit Facility: A single building or facility with multiple separate but adjoining units, each with separate plumbing and possibly other utilities.

NAICS: North American Industry Classification System. The website is found at:  
(<http://www.census.gov/epcd/www/naics.html>)

Series: (Grease Interceptors Installed in Series): Grease interceptor tanks that are installed one after another in a row and are connected by plumbing pipe.

Single Service Kitchen: A FSE that does not prepare food onsite (heat and serve only) and which uses only disposable service ware (utensils and dishes).

Tee or T (Influent & Effluent): A T-shaped pipe extending from the ground surface below grade into the grease interceptor to a depth allowing recovery (discharge) of the water layer located under the layer of FOG. Influent & effluent T's are to be made of PVC schedule 40 or equivalent approved material. Influent T's should extend 2/3 of the grease interceptor water depth, and effluent T's should extend to within 12" to 15" of the bottom of the interceptor tank to prevent short-circuiting.

User: Any person that contributes, causes, or permits the contribution or introduction of wastewater or pollutants into the sanitary sewer system, whether intentional or unintentional, and whether direct or indirect.

Water (Black): Wastewater containing human waste, from sanitary fixtures such as toilets and urinals.

Water (Gray): Wastewater other than black water as defined in this section.

## 5.1 REQUIREMENTS

Grease Control Equipment (GCE) shall be designed and constructed in accordance with the provisions of this FOG Management Policy and/or WSG's Standards and Specifications Manual (see also SD-28 & SD-29).

Minimum acceptable size of GCE for each FSE Classification will be as follows:

Class 1: Deli, Ice Cream shops, Beverage Bars, Coffee Shops, Mobile Food Vendors  
minimum requirement - 25 gallons per minute/50 pound Grease Trap (GT).

Class 2: Limited-Service Restaurants / Caterers 1,000 gallon Grease Interceptor

Class 3: Full Service Restaurants- 1,000 gallon Grease Interceptor

Class 4: Buffet and Cafeteria Facilities- 1,500 gallon Grease Interceptor

Class 5: Institutions (Schools, Hospitals, Prisons, etc)- 2,000 gallon Grease Interceptor  
or two 1000-gallon Grease Interceptors installed in series.

WSG will review GCE sizing information received from the FSE's engineer, architect or contractor. WSG will make a decision to approve, or require additional GCE volume, based on the type of FSE, the number of fixture units, and additional calculations. Grease interceptor capacity should not exceed 2,000 gallons for each interceptor tank. In the event that the grease interceptor calculated capacity needs to exceed 2,000 gallons, the FSE shall install an additional interceptor of the appropriate size. If additional interceptors are required, they shall be installed in series.

Grease interceptors that are installed in series shall be installed in such a manner to ensure positive flow between the tanks at all times. Therefore, tanks shall be installed so that the inlet invert of each successive tank shall be a minimum of 2-inches below the outlet invert of the preceding tank.

Grease Control Equipment (GCE) shall not be located in food preparation areas.

Grease interceptors that are installed in series shall include adaptors, gaskets or flexible transition couplings of minimum of schedule 40 PVC pipe.

Property service connections shall be sized based on fixture units with a minimum size of a 4-inch connection.

All new FSE construction and upgrades having a GCE requirement shall be constructed to include a sample monitoring station designed and approved by WSG.

If an existing undersized GCE is structurally sound and installed properly, then, in lieu of replacing it with a larger unit, the FSE may choose to install an additional unit in series with the existing unit to satisfy the total size capacity required.

New FSE's, as well as existing facilities that are undergoing extensive remodeling shall install and maintain at a minimum, an approved 1,000-gallon grease interceptor located outside the FSE building.

New construction of FSE's shall have separate sanitary (restroom) and kitchen process lines. The kitchen process lines shall be plumbed to appropriately sized GCE. Kitchen process lines and sanitary lines may combine prior to entering the public sewer; however the lines cannot be combined until after the GCE. Sanitary wastewater, or black water, cannot be connected to GCE.

When an existing building and/or building's plumbing is being renovated and the facility is a FSE, internal plumbing shall be reconstructed to separate sanitary (restroom) flow from kitchen process flow. Sanitary flow and kitchen process discharges shall be approved separately by WSG and shall discharge from the building separately. The kitchen process line(s) shall be plumbed to appropriately sized GCE. Kitchen process lines and sanitary lines may combine prior to entering the public sewer; however the lines cannot be combined until after the GCE.

New multi-unit facility, or new strip mall facility, owners shall contact WSG prior to conducting private plumbing work at the multi-unit facility site. Multi-unit facility owners, or their designated contractor, shall have plans for separate private wastewater lines for kitchen and sanitary wastewater for each individual unit. In addition, the plans shall identify stub-out locations to accommodate a minimum 1,000-gallon grease interceptor for each unit of the multi-unit facility. New multi-unit facility, or new strip mall facility owners shall consider suitable physical property space and sewer gradient that will be conducive to the installation of an exterior, in-ground GI when determining the building location.

WSG's Management will review plans for FSE in classes 1 through 5 as part of the building permit acquisition process.

FSE owners or their designee shall submit 3 sets of FSE facility plans to WSG for review and approval.

Facility plans shall include the following sheets: a floor plan detailing kitchen prep equipment and showing how greasy waste lines discharge to GCE, plumbing sheets, and a GCE specification sheets.

All surface water must drain away from the GCE to exclude rainfall from the sewer system.

Traffic locations installations require the top of the interceptor to be below the pavement. Inspection, maintenance, and cleaning manholes must be brought to grade with frames and covers suitable for traffic loads. Plumbing sheets shall include identification of all cooking and food preparation equipment (i.e. fryers, grills, woks, etc); the number and size of dishwashers, sinks, floor drains, and other plumbing fixtures; greasy waste bearing plumbing lines, the location of GCE, and specifications for GCE. The discharge from the following fixtures shall be plumbed to the GCE: all sinks (3-compartment, vegetable prep, mop, etc), dishwashers, floor drains in food preparation and storage areas, garbage disposals, and other fixtures through which grease may be discharged such as woks and soup ladles.

WSG's personnel will review the plumbing plans and GCE sizing; and approve, or make changes as necessary to aid in the protection of a FOG discharge from the FSE.

If the plans are approved by WSG, a First Release will be issued to the FSE.

Personnel from WSG will inspect the GCE. Call 256-574-1515 at least forty-eight (48) hours prior to installation to schedule the inspection. All components of the GCE must be visually inspected before any component is covered. WSG will not accept GCE that has not been inspected and approved by WSG.

If the installed GCE is approved by WSG, a Final Release will be issued to the FSE.

Coffee shops that brew coffee on the premises for consumption and bakeries will not be granted exemptions due to the pH of the wastewater discharged.

Substandard GCE - In the event an existing FSE's GCE is deemed by WSG to be either undersized or substandard in design, the FSE owner(s) will be notified in writing by WSG of the deficiencies and required improvements, and given a compliance deadline not to exceed six (6) months to comply.

## **Prohibitions**

FSE's shall not contribute or cause to be contributed into the WSG collection system the following:

- \* Hot water running continuously through GCE;
- \* Discharge of concentrated alkaline or acidic solutions into GCE;
- \* Discharge of concentrated detergents into GCE.

## 5.2 Certified Hauler/Plumber Program

Participating haulers/plumbers shall:

- Be permitted by the Alabama On-site Wastewater Board to haul waste in the State of Alabama.
- Agree to provide information on GCE to WSG in a timely manner.
- Agree to completely evacuate FOG from GCE when servicing such GCE at FSE's. If the volume of the GCE is greater than the tanker capacity, the hauler/plumber agrees to provide additional tankers so that the GCE is fully evacuated within a 24-hour period.
- Agree to never return gray water removed from GCE to the GCE under any circumstances
- Agree to provide information relative to FOG removed at FSE's in format required by WSG
- Dispose of FOG waste at a facility permitted and authorized to receive such waste in accordance with applicable federal, state and local laws and regulations.
- Perform GCE maintenance in accordance with these guidelines.
- Send scanned copies of service invoices to [wsgwtswforeman@scottsboro.org](mailto:wsgwtswforeman@scottsboro.org)

WSG will provide a listing of all approved haulers/plumbers to FSE's

FSE's under WSG's jurisdiction must have their grease interceptor or grease trap inspected annually to ensure the GCE is in proper working condition. If a grease interceptor or grease trap fails the certification requirement, then a corrective action response is required from the FSE owner or authorized representative by a date specified in the corrective action response.

\* Failure of a Grease Interceptor Certification, or Grease Trap Certification:

The FSE owner or authorized representative is responsible for including detailed Corrective Action Response information on the grease interceptor inspection. At a minimum, the Corrective Action Response information must include the reason for the failed certification, what corrective action will be taken to correct the problem, and the date the corrective action will be completed.

FSE's with GCE shall maintain a log of the pumping/cleaning maintenance activities performed for each GCE on the premises. GCE maintenance records shall include, at a minimum, the date of cleaning/maintenance, company or person conducting the cleaning/maintenance, invoice number of company or person conducting the cleaning/maintenance, FSE name and address, and specific volume of grease wastewater removed from the GCE. Manifests/trip tickets shall be maintained for a period of 3 years to substantiate the maintenance log. However, manifests alone will not meet the requirement. FSE's shall provide compliance reports as requested by WSG.

GCE maintenance records shall be available at the FSE premises so they can be provided to WSG personnel or their representative. The FSE shall maintain GCE maintenance records onsite for three (3) years.

An owner, manager or designated employee of the FSE shall supervise the GCE cleaning/maintenance activities and shall be physically present and observe the entire operation each time cleaning/maintenance is conducted.

Each GCE shall be fully evacuated (complete pump out of GI contents) unless the volume is greater than the tank capacity of the pumper vehicle in which case the hauler shall arrange for additional transportation capacity so that the GCE is fully evacuated within a 24-hour period.

The return of gray water back into the GCE from which the waste was removed is prohibited.

Waste removed from GCE shall be disposed of at a facility permitted and authorized to receive such waste in accordance with applicable federal, state and local laws and regulations. Pumped waste shall not be discharged to a private or public sewer.

FSE's shall observe Best Management Practices (BMP's) for controlling the discharge of FOG from their facility.

### **5.3 Grease Interceptor (GI) Cleaning/Maintenance Requirements**

Grease interceptors must be pumped-in-full when the total accumulations of surface FOG (including floating solids) and settled solids reaches twenty-five percent (25%) of the grease interceptor's overall liquid depth. This criterion is referred to as the 25 Percent Rule. At no time, shall the cleaning frequency of the grease interceptor exceed 90 days, unless approved by WSG. Some existing FSE's in Class 2 through 5 will need to consider a 30 day pumping frequency or a 60 day pumping frequency to meet the 25 Percent Rule requirement.

Partial pump of interceptor contents or on-site pump & treatment of GI contents will not be allowed due to reintroduction of fats, oils and grease to the interceptor and pursuant to the Code Federal Regulation 40 CFR403.5 (b)(8), which states specific prohibitions. In addition, the following pollutants shall not be introduced into a Public Owned Treatment Works (POTW): Any trucked or hauled pollutants, except at discharge points designated by the POTW.

Special pumping frequency approval may be granted by WSG, on a case-by-case basis, for unusual circumstances.

All FSE's in the WSG jurisdiction must have a certified grease waste hauler or plumber complete a grease interceptor certification annually. The grease interceptor certification must be signed by the FSE owner or authorized representative. If a grease interceptor certification fails, then the FSE owner or authorized representative must provide a corrective action response to WSG. The corrective action response will identify the reason for the failure, what corrective action will be taken to correct the problem, and the date the corrective action will be completed.

Grease interceptor effluent-T shall be inspected during cleaning and maintenance and the condition noted by the grease waste hauler's company or individual conducting the maintenance. Effluent-T's that are loose, defective, or not attached must be repaired or replaced immediately.

### **5.4 Grease Trap (GT) Cleaning/Maintenance Requirements**

GT's shall be cleaned of complete fats, oils, and grease and food solids at a minimum of every two (2) weeks, unless more or less cleaning frequency is authorized by WSG. If the FOG and food solids content of the grease trap is greater than 25% of the water depth capacity of the grease trap, then the grease trap shall be cleaned every week, or as frequently as needed to prevent 25% of capacity being occupied with FOG and food solids.

FSE's in the WSG jurisdiction shall have a WSG certified grease waste hauler or plumber complete a grease trap certification annually. The grease trap certification shall be signed by the FSE owner or authorized representative. If a grease trap certification fails, then the FSE owner or authorized representative shall provide a corrective action response to WSG. The corrective action response shall identify the reason for the failure, what corrective action will be taken to correct the problem, and the date the corrective action will be completed.

During cleaning of the grease trap, the flow restrictor shall be checked to ensure it is attached and operational.

Grease Trap waste shall be sealed or placed in a container to prevent leachate from leaking, and then disposed of properly. Disposal of grease trap waste into a sanitary sewer service line or manhole is prohibited.

Grease Trap waste shall not be mixed with yellow grease in the grease recycle container.



## 5.5 Additives

### **Additives are prohibited for use as grease management and control**

Additives include but are not limited to products that contain solvents, emulsifiers, surfactants, caustics, acids, enzymes and bacteria.

If WSG identifies an FSE that is using additives and is contributing FOG to the WSG sewer system, or has caused any interference to the sewer system, the FSE shall immediately stop use of the additive and shall be subject to enforcement action as described in this policy.

At no time shall additives be used just prior to under-the-sink or floor grease traps.

The use of additives is prohibited with the following exceptions:

Additives may be used to clean the FSE drain lines but only in such quantities that it will not cause fats, oils and grease to be discharged from the GCE to the sewer system, or cause temporary breakdown of FOG that will later re-congeal in the downstream sewer system, if the product used can be proven to contain 100% bacteria, with no other additives.

Approval of the use of the product must come from WSG, and the FSE must submit a full disclosure Material Safety Data Sheet and certified sample results from the manufacturer of the product.

The use of approved additives shall in no way be considered as a substitution to the maintenance procedures required per this policy.

### **Right of Entry for Inspection and Monitoring**

WSG shall have the right to enter the premises of FSE's to determine whether the FSE is complying with the requirements of this policy and/or Wastewater Discharge Regulations. FSE's shall allow WSG personnel full access to all parts of the premises for the purpose of inspection, monitoring, and/or records examination. Unreasonable delays in allowing WSG personnel access to the FSE premises shall be a violation of this policy and the Wastewater Discharge Regulations.

WSG may require that the FSE install monitoring or additional pretreatment equipment deemed necessary for compliance with this policy and/or the Wastewater Discharge Regulations.

## 5.6 Enforcement Action

Enforcement action may result against a FSE for instances that include, but is not limited to the following:

- Failure to clean or pump grease control equipment,
- Failure to maintain grease control equipment including inspection and installation of properly functioning effluent-T and baffles,
- Failure to install grease control equipment,
- Failure to control FOG discharge from the FSE,
- Contributing to a sewer line blockage or obstruction,
- Contributing to a Sanitary Sewer Overflow,
- Use of additives in such quantities so that FOG is pushed downstream of the FSE.

Enforcement actions may include the following:

- Requirement of the Food Service Establishment (FSE) to pay all expenses associated with corrective action taken by WSG to clear blockages caused by the failure of the grease control equipment or the failure of the FSE to properly maintain the grease control equipment,
- Termination of all utility services provided by WSG.

**Scottsboro Waterworks, Sewer and Gas Board  
FOG Management Policy  
Fats, Oil, and Grease Interceptor User Compliance Report**

User Information

Business Name: \_\_\_\_\_  
 Physical Address: \_\_\_\_\_  
 Contact Person/Title: \_\_\_\_\_  
 Phone Number: \_\_\_\_\_ Fax Number: \_\_\_\_\_

Type of Facility

- |  |  |                                      |
|--|--|--------------------------------------|
| <input type="checkbox"/> General Restaurant          | <input type="checkbox"/> Fast Food Restaurant    | <input type="checkbox"/> Meat Cutter |
| <input type="checkbox"/> Commercial Food Preparation | <input type="checkbox"/> Institutional Facility  | <input type="checkbox"/> Deli        |
| <input type="checkbox"/> Caterer                     | <input type="checkbox"/> Multi-Family Apartments | <input type="checkbox"/> Bakery      |
| <input type="checkbox"/> Other: _____                |  |                                      |

**Type of Grease Control Equipment (GCE)**

- |   |   |                                    |
|---|---|------------------------------------|
| <input type="checkbox"/> Trap (Indoor access) | <input type="checkbox"/> Interceptor (Outdoor access) | <input type="checkbox"/> Separator |
| <input type="checkbox"/> Common Interceptor   | <input type="checkbox"/> Combination of Devices       | <input type="checkbox"/> Screens   |
| <input type="checkbox"/> Other: _____         | <input type="checkbox"/> None                         |                                    |

Waste Hauler/Pumper Information

List Company Name, Invoice Number, and Date of the last six times your grease control equipment was pumped out or cleaned.

Hauler/Pumper Company Name	Invoice Number	Date
_____	_____	_____
_____	_____	_____
_____	_____	_____
_____	_____	_____
_____	_____	_____

I certify that the above information is accurate and that the Grease Control Equipment was pumped out and cleaned by the pumper/hauler of record on the date as stated.

User Signature: \_\_\_\_\_ Date: \_\_\_\_\_

## Section 6.0

### SPECIFICATIONS FOR RESIDENTIAL GRINDER PUMPS

#### 6.1 General

1. Scope

The manufacturer shall furnish and deliver fully the assembled grinder pump station to the contractor or owner. Simplex units, containing one grinder pump and all necessary parts and equipment shall be factory installed, except for externally mounted control panel, gravity sewer inlet, hubs and pump assembled, which needs to be installed in the field. Each pre-assembled simplex station shall include the basin, basin cover, grinder pump and motor, quick disconnect rail system, check valve, start-stop level controls, motor high temperature shutoff, motor seal leak alarm, high water alarm, shutoff valve and schedule 40 discharge piping. In addition, an external alarm and pump control panel is to be provided for each unit. Electrical wiring shall be continuous from the motor to the control panel. No splices are allowed.

2. Grinder pump

- i. Operating conditions – each grinder pump shall be of the centrifugal design and be capable of delivering minimum of 25 GPM at 84 feet head. The shutoff head shall be no less than 105 feet.
- ii. Pump- The pump shall have an integrally built in grinder unit and submersible type motor. The pump shall be suspended in the basin by two (2) 1” guide rails and quick disconnect lift out mounting assembly. Solids shall be fed in an up flow direction to the grinder mechanism with no obstructions below the grinder inlet. The grinder unit shall be capable of cutting solid material found in normal domestic sewage, including reasonable amount of foreign objects, such as wood, plastic, glass, rubber, sanitary napkins, disposable diapers and panty hose into a fine slurry that will pass freely through the pump, service line and force main.
- iii. Motor- The pump motor shall be of the submersible type rated for 2-horse power at 3450 RPM. Motor shall be single phase, 230 volt, and 60 hertz. Single-phase motor shall be of the capacitor start- capacitor run type for high starting torque. The stator winding shall be the open type with class B insulation rate for 130 degrees C maximum operating temperature. The winding housing will be filled with clean dielectric oil that will lubricate bearings seals and transfer heat from the windings to the outer shell. The motor stator is to be pressed into the motor housing for optimum concentricity and alignment and maximum heat transfer. The motor shall be capable of operating over full range of performance curve without overloading motor and causing any objectionable noise vibration. The motor shall have two bearings to support the rotor, an upper ball bearing to accommodate thrust loads and a lower ball bearing to take radial loads. Ball bearings shall be designed for 10 life (50,000 hours). A heat sensor thermostat and overload shall be attached to the top end of the motor windings and shall stop the motor if the motor winding temperature reaches 200 degrees F. The high temperature shut off will cause the pump to cease operation should a control failure cause the pump to run in a dry wet well. The thermostat shall reset automatically when the motor cools to a safe operating temperature.
- iv. Power Cord- The motor power cord shall be 14-5 SOW/SOW-A and shall be fastened by means of a cord grip in the top the pump. The top of the pump shall contain a waterproof junction box, which will provide space to connect the power cord and the motor leads. The motor leads shall seal between the motor housing and the junction box by means of a rubber compression fitting around each wire.
- v. Seal Chamber- the motor shall be protected by two (2) rotary shaft seals mounted in tandem with oil filled chamber separating the seals. The seals shall have carbon and ceramic seal faces diamond lapped to a tolerance of one light band. Metal parts and springs for seals shall be stainless steel. An electrical sensing probe shall be mounted in the seal chamber to detect any water leakage past the lower seal.

- vi. Pump Impeller- The pump impeller shall be of the recessed type to provide an open unobstructed passage through the volute for the ground solids. The impeller shall be constructed of cast iron and shall have pump out vanes on the backside of the impeller to keep solids from lower seal and reduce pressure at the seat faces. Impeller shall be threaded onto the stainless steel shaft.
- vii. The grinder assembly shall consist of a rotating radial cutter and a stationary shredding ring, and shall be mounted directly below the volute passage. The rotating cutter shall be threaded onto the stainless steel shaft and shall be locked with a screw and washer. The stationary shredding ring shall be pressed onto an iron holding flange for easy removal. The flange shall be provided with tapped back-off holes so that screws can be used to push the shredding ring from the housing. Both the cutter and shredding shall be removable from the outside without dismantling pump. Grinder assembly shall be of such construction that no clearance adjustments are required when assembling. All grinding solids shall be from the action of the radial cutter against the shredding ring. The radial cutter and shredding ring shall be of #440 stainless steel hardened to 58-60 Rockwell C.
- viii. Pump and Motor Castings- All iron casting shall be of high tensile cast iron and shall be properly cleaned, pre-treated with chromic rinse, and painted with high quality enamel paint. All pump components that are not cast iron or stainless steel shall be galvanized or painted with baked on epoxy. All fasteners shall be #302 stainless steel.
- ix. Plug – in Connector – A waterproof male plug shall be supplied on the pump power and control cord and shall mate to a female socket mounted in the junction box. The plug and cord shall be of the proper size to handle the voltage and current requirements of the pump. The plug and receptacle shall be of the molded to cable and double face design. The female half shall fit like a cork into the flexible shroud portion of the male. In addition, individual neoprene shoulders around contacts shall fit into recesses in female section. The cable shall be neoprene molded, one-piece design, and the connector shall have threaded coupling for positive tight connection and quick release. The mating connectors shall have an indexing tab to insure proper alignment.
- x. Basin Assembly- Basin – The basin shall be 24” diameter. A minimum 2.5-foot holding capacity below the inlet hub will be required. The basin shall be molded of fiberglass reinforced polyester resin manufactured by the lay-up and spray technique to assure that the interior surface is smooth and resin rich. The basin shall have a minimum wall thickness of ¼ inch. An anti-flotation collar shall be molded into the bottom of the basin and shall extend a minimum of 3” around the outside diameter of the basin. The cover shall be 3/8” polypropylene. The cover shall be bolted to the basin with stainless steel cap screws. Cadmium plated nuts for the screws shall be embedded in the fiberglass prevent turning and for corrosion resistance. Shutoff Valve- PVC true union ball type shutoff valve with Teflon seats shall be furnished and installed in the discharge piping. If the discharge depth is more than 2 feet from the surface, a handle extension shall be supplied. Rail Assembly- A lift-out guide rail assembly shall permit easy removal and installation of the pump and lower check valve without the necessity of personnel entering the basin. Structural PVC guide brackets with guide yokes of sufficient bearing strength to prevent binding shall bolt to the pump. The yokes shall mate over guide rails of a minimum of 1 “ fiberglass pipe running between an upper rail support and the cast iron discharge case. A lower discharge nozzle, downstream from the check valve, shall be guided into a chamfered cavity in the discharge case. A shoulder on the nozzle shall bottom on the discharge case when the pump is properly located and shims shall not be required to insure alignment for a leak tight seal. Dual “o” rings shall affect a hydraulic seal around the nozzle when it is in its operating position. A brace, easily removable from the top of the basin, shall be provided to lock the parts together, preventing line surges from breaking the seal and allowing leakage. The discharge case shall have a discharge opening with piping to a coupling through the basin wall. The discharge case shall be securely bolted to the basin floor and arranged in such a way that slight deflection caused by the discharge will not cause the quick-connect pump flange to leak. A lifting chain shall be securely fastened to the top of the

pump and to the top of the basin to facilitate removal of the pump. The chain shall be minimum of ¼ “ welded link type or of adequate strength, required to effectively support the weight of the pump assembly while removing and installing.

- xi. Piping – Schedule 40 Discharge piping shall connect to the stationary discharge base lift assembly and terminate at a 2” discharge flange mounted on the basin.
- xii. Check Valve – a heavy-duty spring-loaded all rubber flapper type check valve with cast iron body shall be an integral part of the discharge seal assembly and shall lift out with the pump assembly. The valve design shall be such to allow for operation when negative heads of up to 5 feet are encountered. The valve shall be designed to operate at all pressures in the sewer system created by the grinder pumps. A flat stainless steel spring, integrally molded into the buna N rubber flapper shall be furnished in order to prevent collection of debris in the check valve. All fasteners shall be stainless steel.
- xiii. Inlet Flange- A basin inlet flange for 4” schedule 40 plastic pipes shall be included but not mounted on the basin. The flange is to be mounted in the field at inlet height required by the installation.
- xiv. Anti-Siphon Valve- shall be installed on the pump discharge line between the check valve and the gate valve. The anti-siphon valve shall be made of PVC and will not interfere with pump removal or installation.
- xv. Electrical- Control Panel- A NEMA 4X fiberglass control panel shall be furnished with each pumping unit to be installed. The control panel enclosure shall be 14”x 12”x 5-7/8” and molded of glass reinforced polyester resins which are chemically resistant to corrosive atmospheres. The resin system shall be pigmented to impart a gray color to the enclosure and be resistant to ultraviolet light. The resin system also shall include a flame retardant to obtain a flammability rating which meets U.L 94 V-O. Heat distortion temperature shall be 350 degrees Fahrenheit. The enclosure shall be of one-piece, weather –proof construction with smooth, rounded corners and shall be constructed to have a smooth exterior and interior. The enclosure shall be fitted with a closed cell neoprene gasketed cover. The enclosure shall be provided with back pane mounting provisions. The cover shall be hinged with a heavy-duty corrosion resistant stainless steel piano hinge. The cover shall be lockable by means of two (2) high quality combination stainless steel latches and padlock hasps. The enclosure shall be provided with external mounting feet on the top and bottom of the enclosure. These mounting feet shall be of fiberglass and molded as an integral part of the enclosure. The panel shall include a double pole 20 amp main disconnect breaker alarm circuit fuse, control fuse, control circuit fuse, L.E.C. rate motor contractor, Klison overload, pump hand-off- auto switch (momentary in the hand position), pump run light, seal leak light, start and run capacitors, start relay, terminal blocks, ground lug (rated for 6GA to 14 GA wire), and all necessary wiring and brackets. The control panel shall be fitted with and red leaxan alarm light. The light shall be approximately 3” high by 3 ½ “ diameter. The globe shall be mounted on the top of the enclosure with a neoprene gasket. The lens cannot be removed from the exterior of the enclosure. Entering the interior of the enclosure and removing four screws may remove the lens. The bulb shall be 40-watt minimum high intensity-medium base type. The bulb shall be easily replaced by removing a thumbscrew from the support bracket on the interior of the panel. The alarm shall have bright glow and flash during the high water conduits. The alarm light will go out when the water level drops. All internal wiring shall be neat and color-coded. Each wire shall be a different color or stripe and all incoming wires shall terminate into a box clamp type terminal block. All wires shall be 14 GA type TEW rated for 105 degrees Celsius. A schematic diagram shall be permanently fastened to the inside of the enclosure. An installation and service manual shall also be included with each control panel. The control panel shall be U.L. listed as an assembly. All electrical wiring shall meet standard electrical code requirements.

## **6.2 Low Pressure System Design**

1. Piping must be slip joint, mechanical joint or butt fused.

2. Pipe must be class 200 PVC (SDR-21) or DR 11 High Density Polyethylene with green stripe.
3. Services to have a full port ball valve and a ball check.
4. Clean out to include a full port ball valve on each cleanout.
5. Locating wire for the system will be 12-gauge green.  
(see Typical Residential Grinder Pump Installation Detail SD-21)

### **6.3 High Pressure System Design**

1. Piping must be slip joint, mechanical joint or butt fused.
2. Pipe must be class 200 PVC (SDR-21) or DR 11 High Density Polyethylene with green stripe.
3. Services to have a full port ball valve and a double ball check.
4. Clean out to include a full port ball valve on each cleanout.
5. Locating wire for the system will be 12-gauge green.  
(see Typical Residential Grinder Pump Installation Detail SD-20)

## Section 7.0

### SMALL CAPACITY DUPLEX SUBMERSIBLE PUMP STATION

#### 7.1 General Design Criteria

(see Typical Design Details SD-25 & SD-26)

- Minimum site dimension 30 feet x 30 feet
- Fenced site with gate, graveled lot, vehicle access
- Security light
- ¾" Water Meter
- Influent manhole with one inlet to pump basin
- Dexter-Fortson RTU with radio communications to host SCADA computer
- Three phase power supply (Adequately sized for future upgrade)
- Two (2) Myers 5 HP (minimum)-3 phase-230 volt - 4" non-clog pumps (or approved equal)
- Power cords must be one-piece construction with sufficient length to extend from the pump to the control panel. Splices will not be permitted.
- Duplex Control Panel with high water alarm and time meters (Uni-strut support bracket within 2 feet of basin)
- Terminal Strip for telemetry connections
- Minimum 60 inch diameter concrete basin with a minimum 5ft holding capacity below influent pipe
- All interior hardware, fasteners, and supports shall be stainless steel
- Stainless steel guide rails (Adequately sized guide rails for future upgrade)
- Stainless steel guide brackets
- Stainless steel lifting chain
- Stainless steel float bracket
- 4" Ductile Iron discharge piping
- Myers Floats with ample cord lengths (or approved equal)
- Flanged Cast Iron Internal Weighted Discharge Check Valve
- Concrete vault with aluminum hatch (to house check and gate valves, pressure gauges)
- Aluminum Basin Cover with stainless steel hardware
- Stainless Steel Basin vent
- This list is a guide for basic design. An experienced licensed professional engineer must make a determination of required pump size on a site-by-site basis.
- All submittals must be approved by Scottsboro Waterworks, Sewer & Gas Board

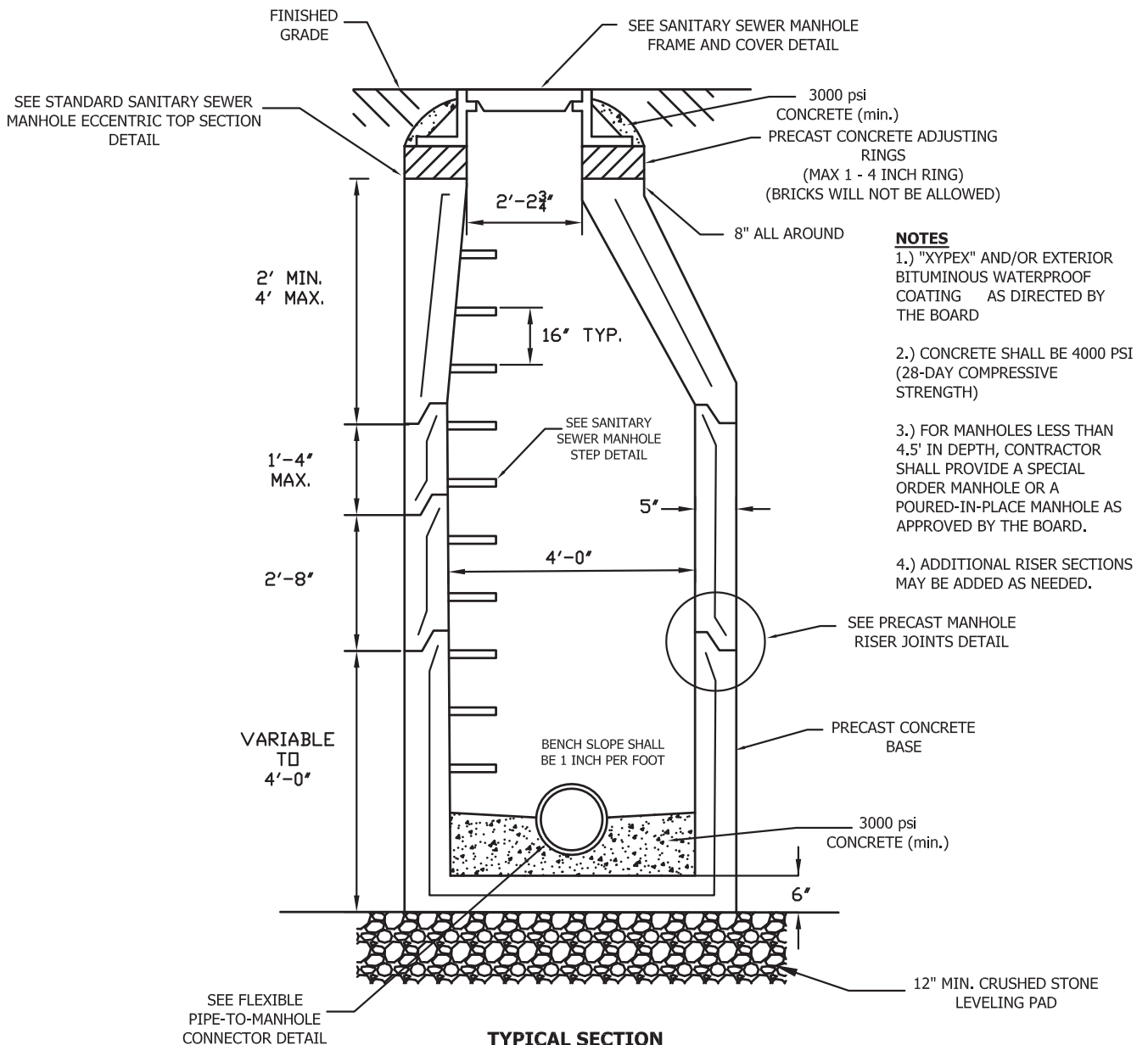

**TYPICAL SECTION**

(BASE SECTION FOR 6" TO 24" PIPE SHOWN)

<p><b>SCOTTSBORO WATER, SEWER &amp; GAS BOARD</b></p> <p><b>SANITARY SEWER CONSTRUCTION STANDARD DETAILS</b></p> <p><b>404 E. WILLOW ST. SCOTTSBORO, AL 35768</b></p> <p><b>PHONE: (256) 574-1515 FAX: (256) 574-1965</b></p>	<b>SD-1</b>
	STANDARD SANITARY SEWER MANHOLE
	APPROVED BY: R.E.L.
	DATE IMPLEMENTED: 7/21/09
	REVISIONS:



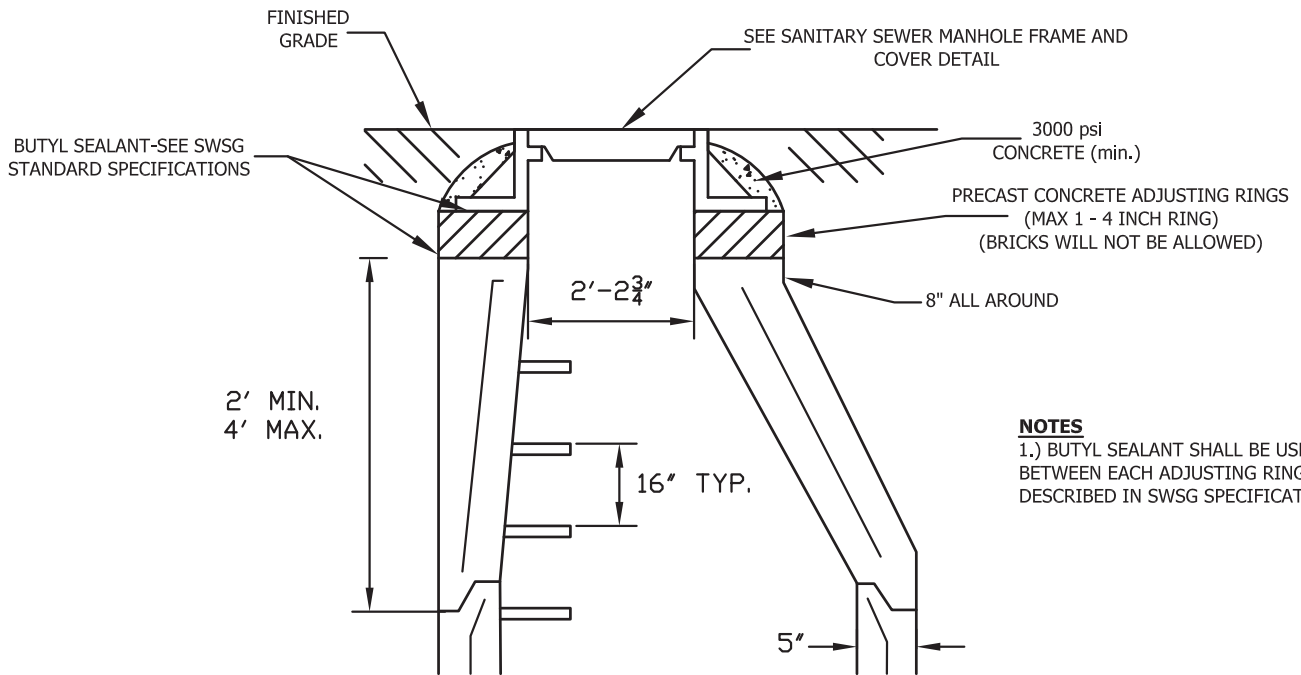

**NOTES**  
 1.) BUTYL SEALANT SHALL BE USED BETWEEN EACH ADJUSTING RING AS DESCRIBED IN SWSG SPECIFICATIONS.

<p><b>SCOTTSBORO WATER, SEWER &amp; GAS BOARD</b></p> <p><b><i>SANITARY SEWER CONSTRUCTION STANDARD DETAILS</i></b></p> <p><b>404 E. WILLOW ST. SCOTTSBORO, AL 35768</b></p> <p><b>PHONE: (256) 574-1515 FAX: (256) 574-1965</b></p>	<h1>SD-2</h1>
	<p>SANITARY SEWER MANHOLE ECCENTRIC TOP SECTION DETAIL</p>
	<p>APPROVED BY: R.E.L.</p>
	<p>DATE IMPLEMENTED: 7/21/09</p>
	<p>REVISIONS:</p>

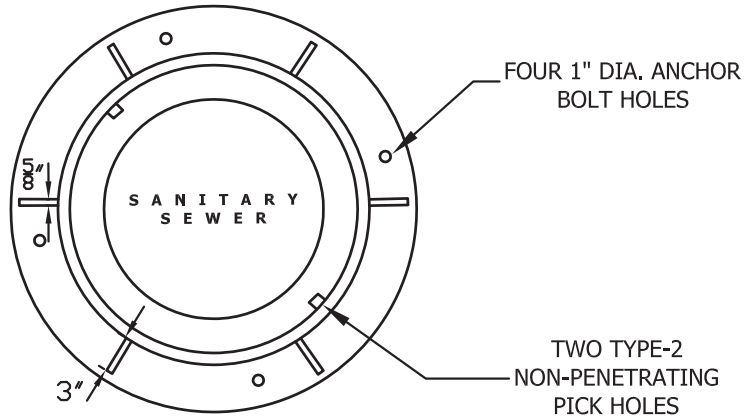

**COVER & FRAME**

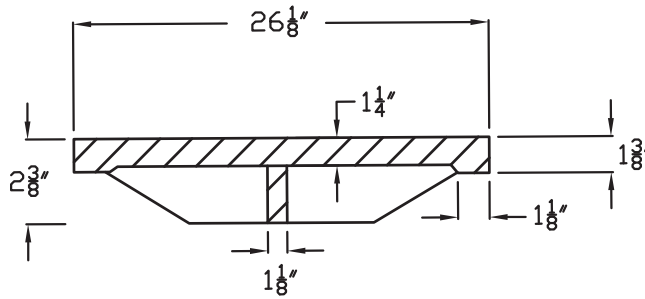

**COVER**

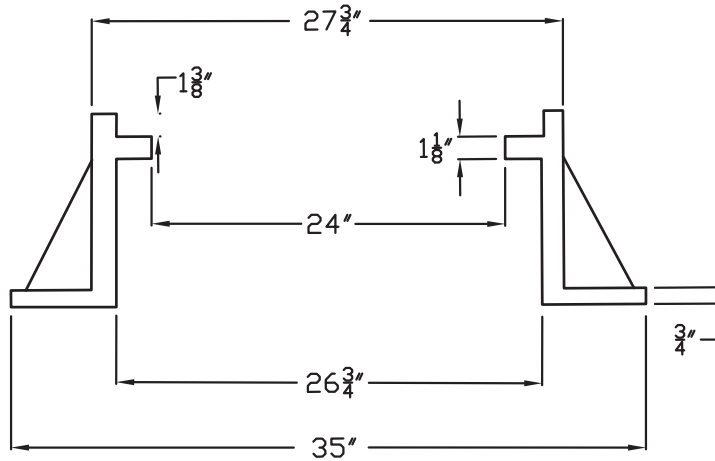

**FRAME**

**NOTES**

- 1.) JOHN BUCHARD FOUNDRY 1155 FRAME AND COVER OR APPROVED EQUAL.
- 2.) BUTYL SEALANT SHALL BE USED TO SEAL FRAME OF MANHOLE AS DESCRIBED IN THE SWSG SPECIFICATIONS.
- 3.) RING AND COVER MUST BE BOLTED TO MANHOLE CONE.

**SCOTTSBORO WATER, SEWER & GAS BOARD**

***SANITARY SEWER CONSTRUCTION STANDARD DETAILS***

**404 E. WILLOW ST.  
SCOTTSBORO, AL 35768**

**PHONE: (256) 574-1515  
FAX: (256) 574-1965**

**SD-3**

**MANHOLE  
FRAME AND COVER**

APPROVED BY: R.E.L.

DATE IMPLEMENTED: 7/21/09

REVISIONS: 8/8/17

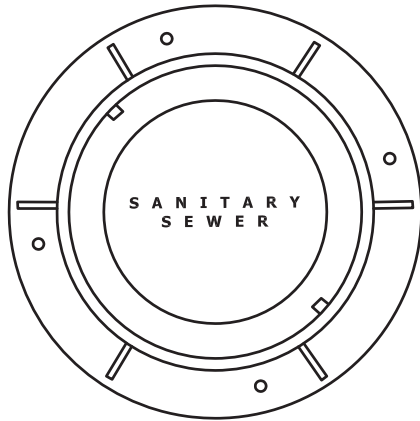

**NOTES**

- 1.) RING AND COVER MUST BE BOLTED TO MANHOLE CONE.

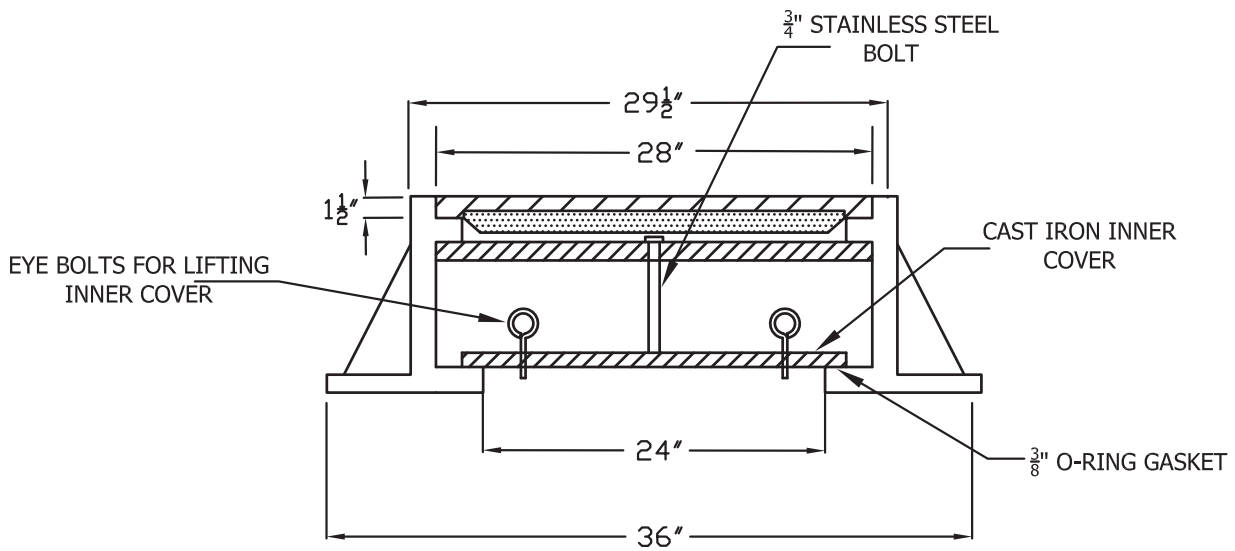

<p><b>SCOTTSBORO WATER, SEWER &amp; GAS BOARD</b></p> <p><b><i>SANITARY SEWER CONSTRUCTION STANDARD DETAILS</i></b></p> <p><b>404 E. WILLOW ST. SCOTTSBORO, AL 35768</b></p> <p><b>PHONE: (256) 574-1515 FAX: (256) 574-1965</b></p>	<b>SD-4</b>
	INNER WATER-TIGHT TRAFFIC RATED MANHOLE COVER
	APPROVED BY: R.E.L.
	DATE IMPLEMENTED: 7/21/09
	REVISIONS:

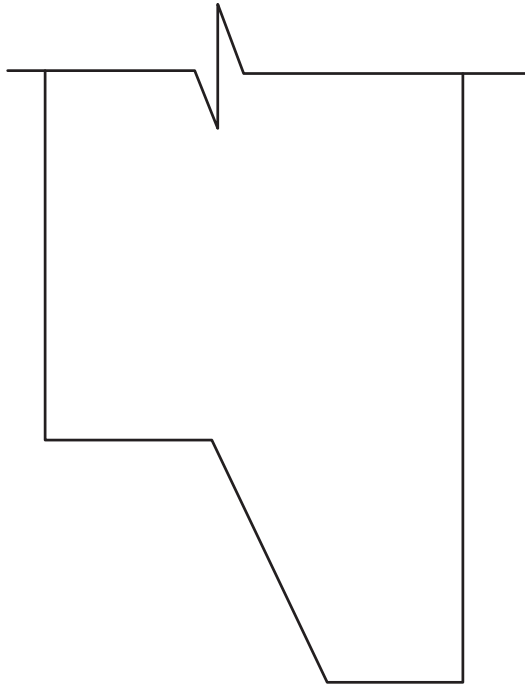

**NOTES**

1.) ALL JOINTS SHALL BE OF SUCH DESIGN TO PERMIT EFFECTIVE JOINING WITH NO LEAKAGE, NO INFILTRATION AND TO PERMIT PLACEMENT WITHOUT APPRECIABLE IRREGULARITIES ON THE INTERIOR WALL.

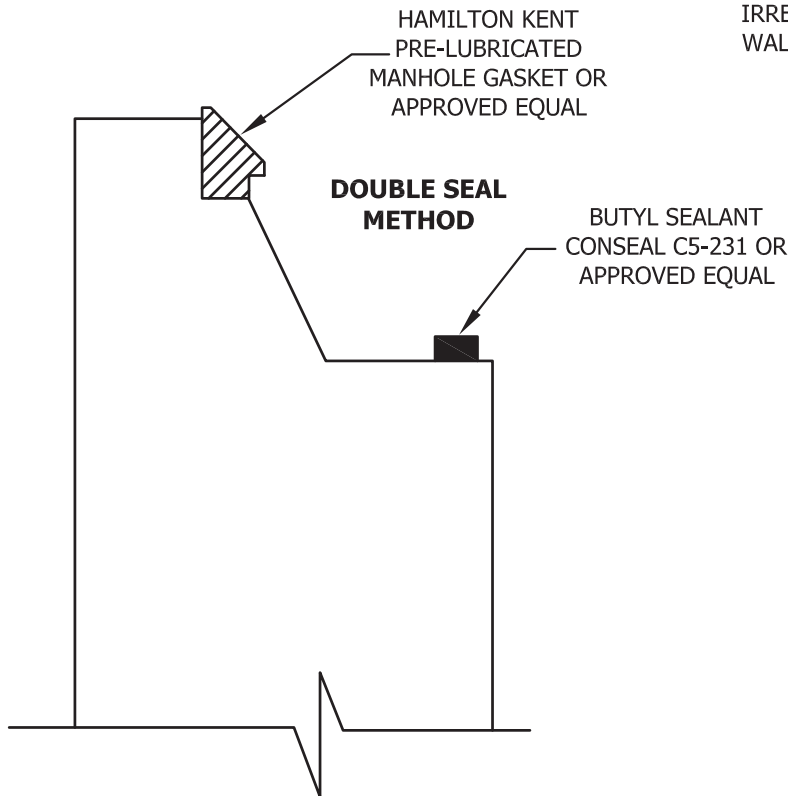

**SCOTTSBORO WATER, SEWER & GAS BOARD**

***SANITARY SEWER CONSTRUCTION STANDARD DETAILS***

**404 E. WILLOW ST.  
SCOTTSBORO, AL 35768**

**PHONE: (256) 574-1515  
FAX: (256) 574-1965**

**SD-5**

PRECAST MANHOLE RISER JOINT

APPROVED BY: R.E.L.

DATE IMPLEMENTED: 7/21/09

REVISIONS:

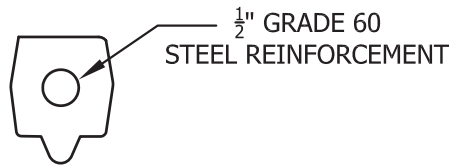
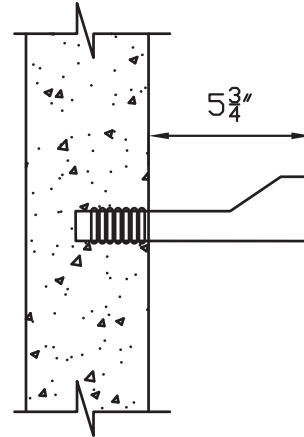
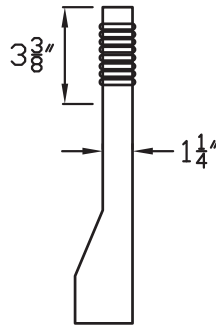
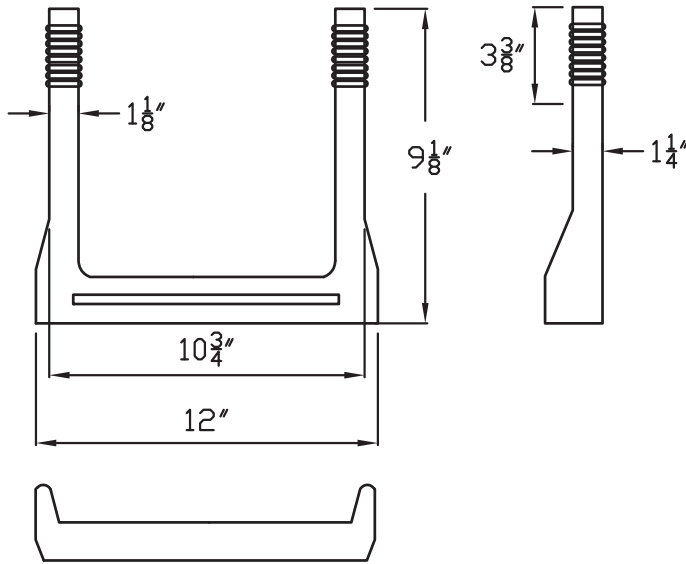
**NOTES**

- 1.) MANHOLE STEPS SHALL BE MANUFACTURED FROM ALUMINUM (ALLOY 6057-Y6) OR POLYPROPYLENE PLASTIC REINFORCED WITH A 1/2" GRADE 60 STEEL ROD.
- 2.) STEPS SHALL BE EMBEDDED IN THE RISER BASE AND TOP SECTIONS A MINIMUM OF 0'-3" AT THE TIME OF CONSTRUCTION.
- 3.) STEPS SHALL BE A MINIMUM OF 10 3/4" WIDE AND EXTEND FROM THE MANHOLE WALL A MINIMUM OF 5 3/4".

**SCOTTSBORO WATER, SEWER & GAS BOARD**

**SANITARY SEWER CONSTRUCTION STANDARD DETAILS**

**404 E. WILLOW ST.  
SCOTTSBORO, AL 35768**

**PHONE: (256) 574-1515  
FAX: (256) 574-1965**

**SD-6**

MANHOLE STEP

APPROVED BY: R.E.L.

DATE IMPLEMENTED: 7/21/09

REVISIONS:

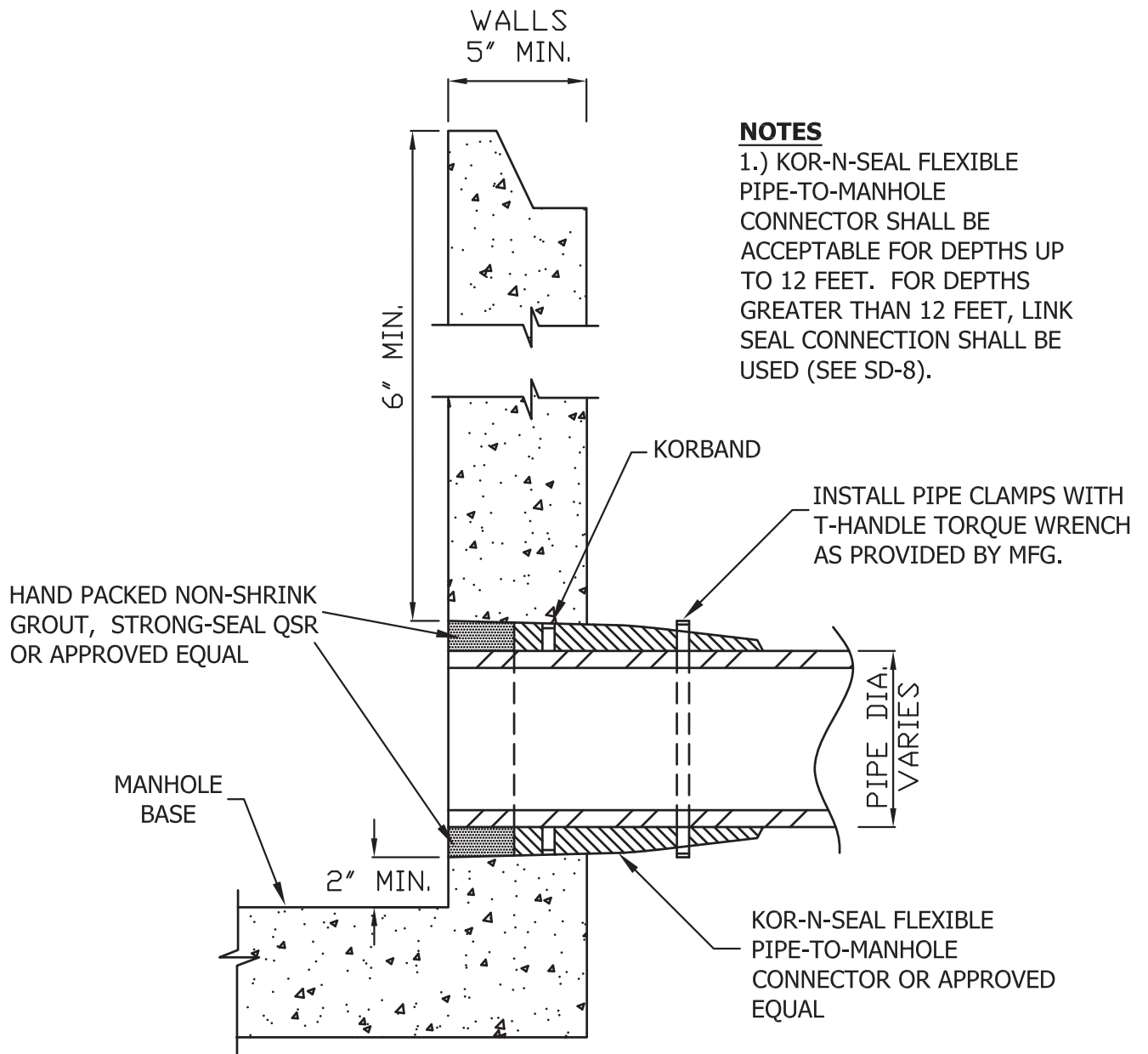
<p><b>SCOTTSBORO WATER, SEWER &amp; GAS BOARD</b></p> <p><b>SANITARY SEWER CONSTRUCTION STANDARD DETAILS</b></p> <p><b>404 E. WILLOW ST. SCOTTSBORO, AL 35768</b></p> <p><b>PHONE: (256) 574-1515 FAX: (256) 574-1965</b></p>	<p><b>SD-7</b></p>
	<p>FLEXIBLE PIPE-TO-MANHOLE CONNECTOR</p>
	<p>APPROVED BY: R.E.L.</p>
	<p>DATE IMPLEMENTED: 7/21/09</p>
	<p>REVISIONS:</p>
	<p> </p>
	<p> </p>

**NOTES**

1.) LINK SEAL SHALL BE USED ON ALL WET WELL APPLICATIONS AS WELL AS ANY CONNECTIONS AT DEPTHS OF 12 FEET OR GREATER.

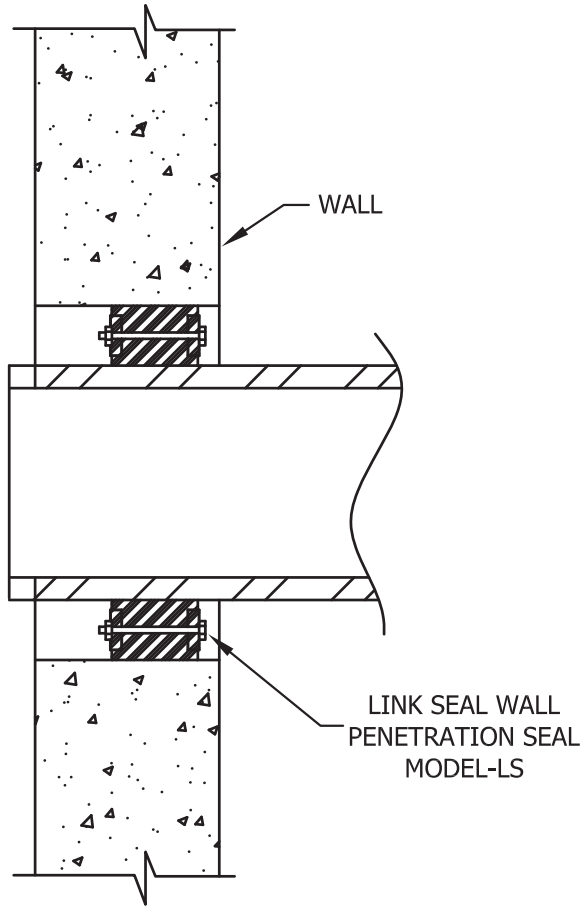

**Model "S-316" Link-Seal Modular Seal**

For chemical processing waste water treatment. EPDM rubber is resistant to most inorganic acids and alkalis, some organic chemicals (acetone, alcohol, ketones).

**Color:** Black

**Type:** Stainless

**Seal Element:** EPDM (Black)

**Pressure Plates:** Composite

**Bolts & Nuts:** 316 Stainless Steel

**Temp. Range:** -40 to +250F. (-40 to +121C.)

<b>SCOTTSBORO WATER, SEWER &amp; GAS BOARD</b>  <b><i>SANITARY SEWER CONSTRUCTION STANDARD DETAILS</i></b>  <b>404 E. WILLOW ST. SCOTTSBORO, AL 35768</b>  <b>PHONE: (256) 574-1515 FAX: (256) 574-1965</b>	<b>SD-8</b>
	LINK SEAL
	APPROVED BY: R.E.L.
	DATE IMPLEMENTED: 7/21/09
	REVISIONS:

**INSIDE DROP NOTES**

- 1.) CLAMPS TO BE 1 1/2" X 12 GAUGE STAINLESS STEEL ANCHORED TO MANHOLE WALL WITH 2 1/2" CADMIUM PLATED BOLTS.
- 2.) PIPE TO BE PLACED AS CLOSE AS POSSIBLE TO MANHOLE WALL.
- 3.) TREATED WOOD SPACERS TO BE PLACED BETWEEN PIPE AND MANHOLE WALL MID WAY BETWEEN CLAMPS.

90° ELBOW  
EMBEDDED IN CONCRETE  
(TURNED AT 45° WITH  
SEWER FLOW)

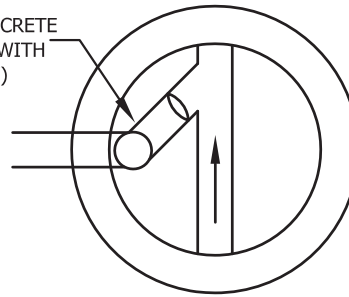

**INSIDE DROP CONNECTION (PLAN VIEW)**

**OUTSIDE DROP NOTES**

- 1.) DROP CONNECTION PIPE TO BE THE SAME AS THE LATERAL. MECHANICAL JOINT FITTINGS ONLY.
- 2.) A TEE MAY BE USED INSTEAD OF A WYE.

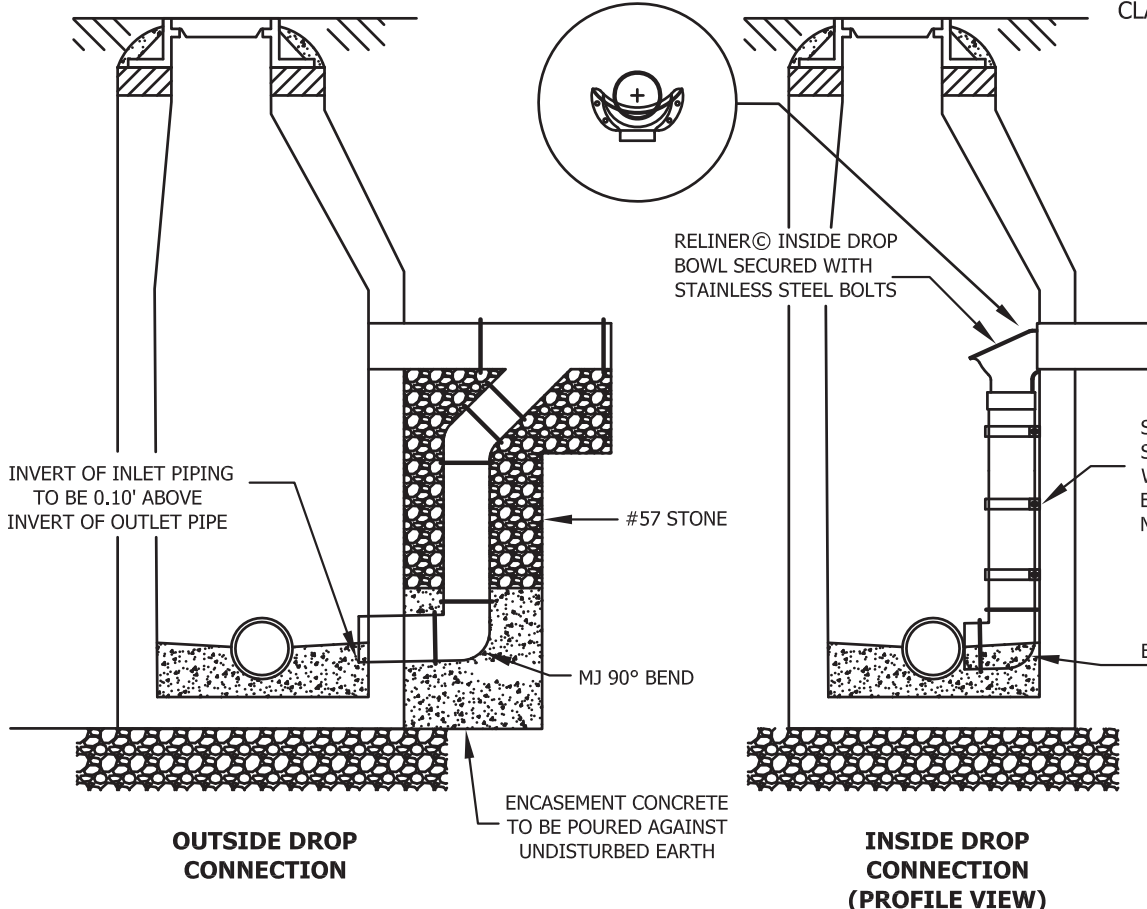

**OUTSIDE DROP CONNECTION**

**INSIDE DROP CONNECTION (PROFILE VIEW)**

**SCOTTSBORO WATER, SEWER & GAS BOARD**

**SANITARY SEWER CONSTRUCTION STANDARD DETAILS**

**404 E. WILLOW ST.  
SCOTTSBORO, AL 35768**

**PHONE: (256) 574-1515  
FAX: (256) 574-1965**

**SD-9**

MANHOLE DROP CONNECTION

APPROVED BY: R.E.L.  
DATE IMPLEMENTED: 7/21/09  
REVISIONS:

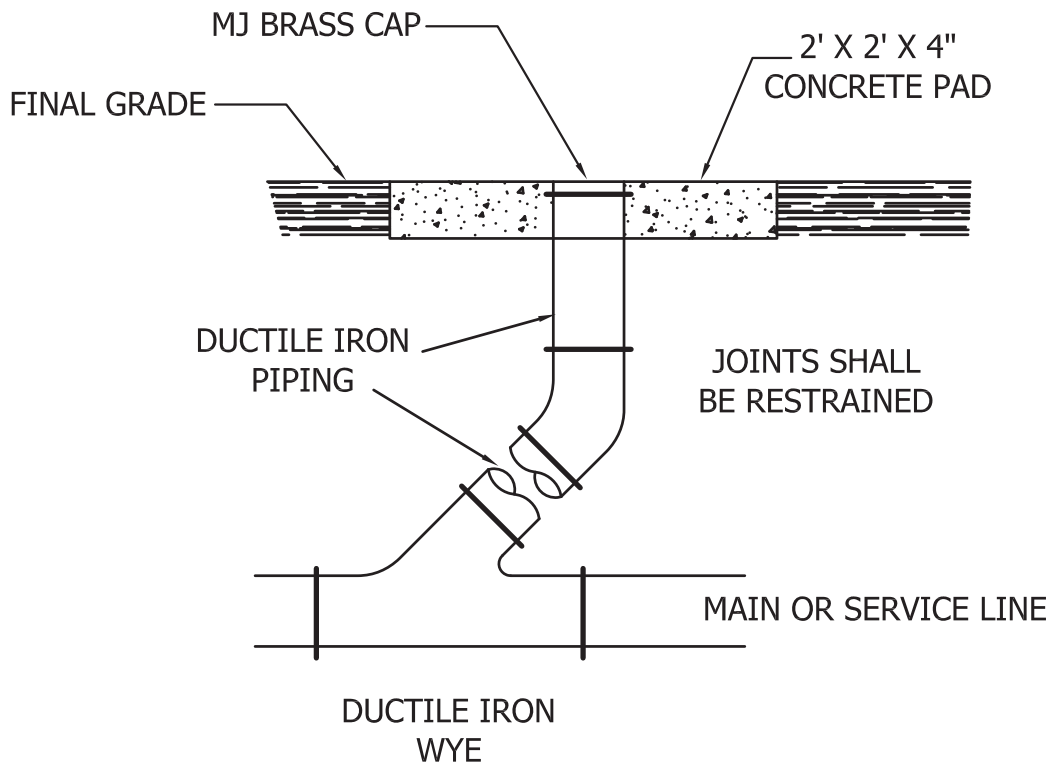

<p><b>SCOTTSBORO WATER, SEWER &amp; GAS BOARD</b></p> <p><b><i>SANITARY SEWER CONSTRUCTION STANDARD DETAILS</i></b></p> <p><b>404 E. WILLOW ST. SCOTTSBORO, AL 35768</b></p> <p><b>PHONE: (256) 574-1515 FAX: (256) 574-1965</b></p>	<h1><b>SD-10</b></h1>
	<p>CLEANOUT IN TRAFFIC AREAS</p>
	<p>APPROVED BY: R.E.L.</p>
	<p>DATE IMPLEMENTED: 7/21/09</p>
	<p>REVISIONS:</p>

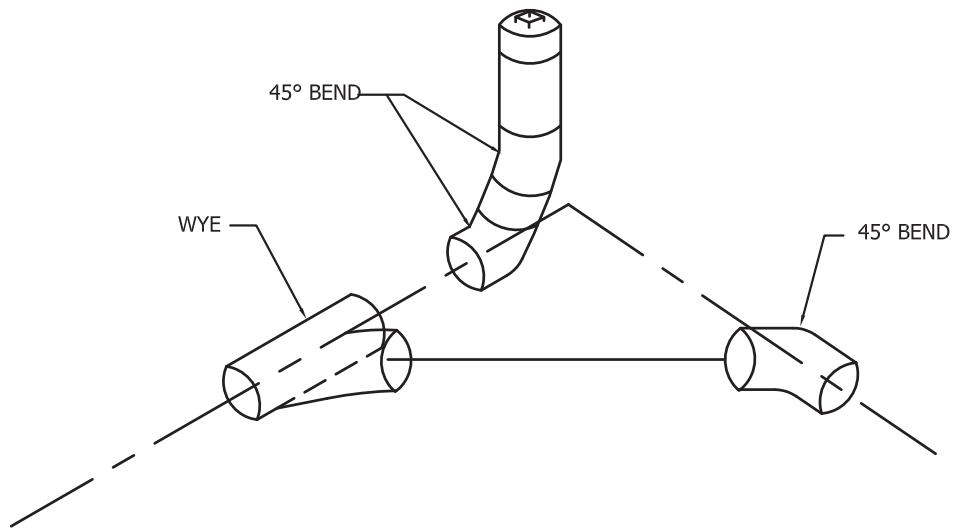

**90° ALIGNMENT  
CHANGE**

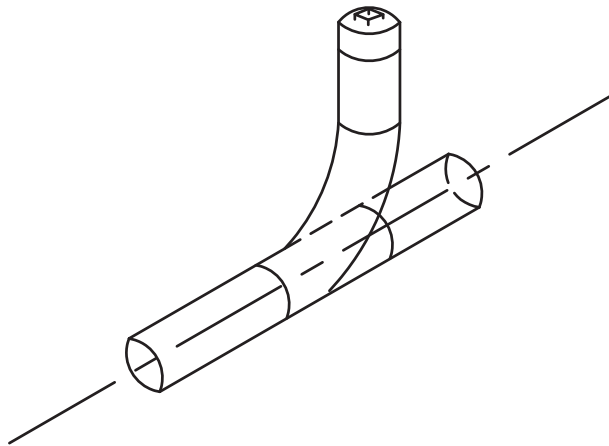

**NO ALIGNMENT  
CHANGE**

<p><b>SCOTTSBORO WATER, SEWER &amp; GAS BOARD</b></p> <p><b><i>SANITARY SEWER CONSTRUCTION STANDARD DETAILS</i></b></p> <p><b>404 E. WILLOW ST. SCOTTSBORO, AL 35768</b></p> <p><b>PHONE: (256) 574-1515 FAX: (256) 574-1965</b></p>	<h1><b>SD-11</b></h1>
	<p>TYPICAL CLEANOUT ALIGNMENT</p>
	<p>APPROVED BY: R.E.L.</p>
	<p>DATE IMPLEMENTED: 7/21/09</p>
	<p>REVISIONS:</p>
	<p> </p> <p> </p> <p> </p>

**NOTES**

- 1.) PVC PIPING SHALL BE 4" SCHEDULE 40 FROM THE MAIN TO THE CLEAN-OUT.
- 2.) CELL-CORE PIPE IS NOT ACCEPTABLE.
- 3.) ALL PIPING SHALL BE DUCTILE IRON CLASS 350 IN AREAS WITH LESS THAN 3- FEET OF COVER OR MORE THAN 12- FEET OF COVER.
- 4.) MECHANICAL JOINTS REQUIRED ON DUCTILE IRON PIPE.
- 5.) SANITARY SEWER BOX IS A PLASTIC BOX. THIS DETAIL NOT FOR USE IN AREAS OF TRAFFIC. SEE SD-10 FOR TRAFFIC RATED CLEAN-OUT DETAIL.

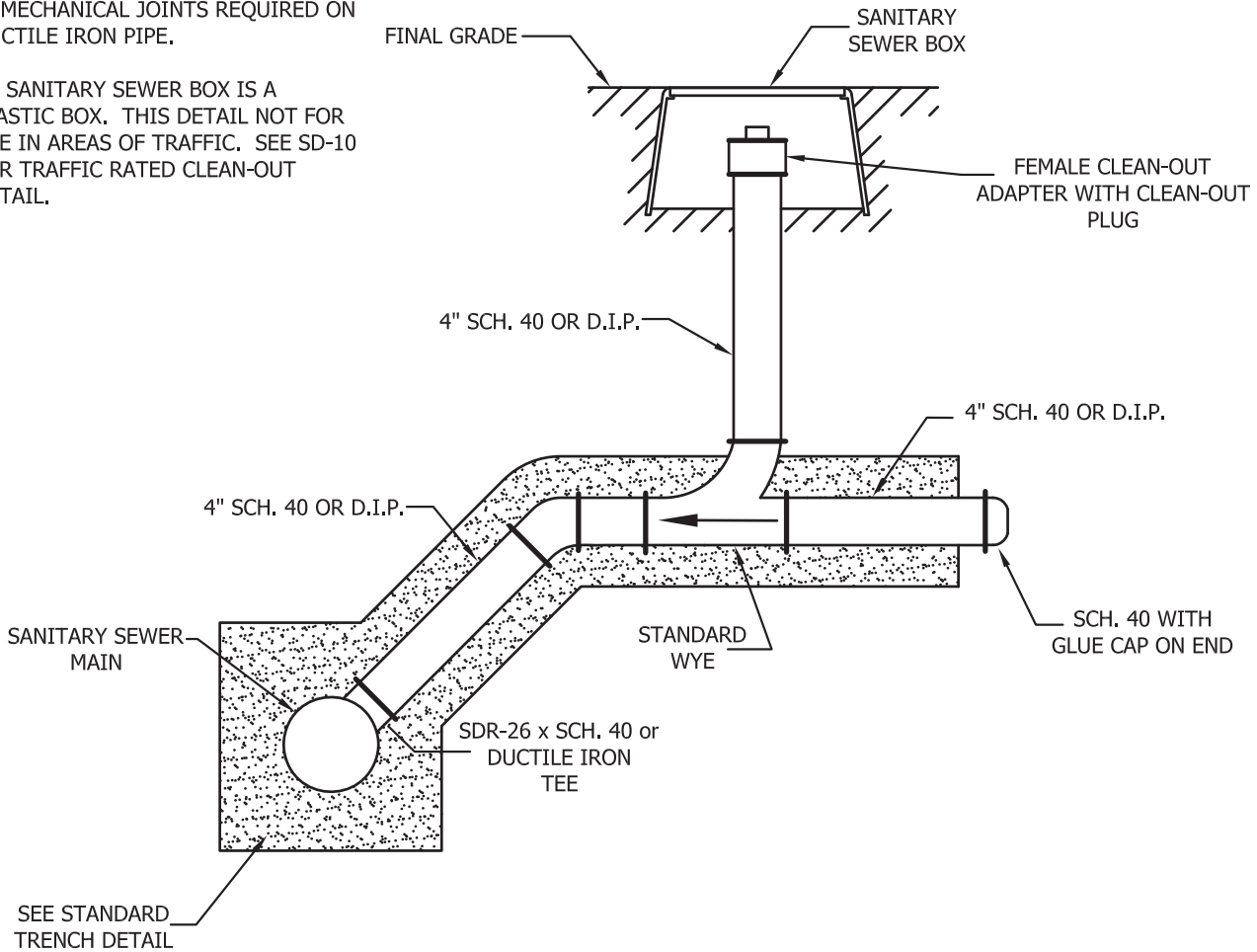

<p><b>SCOTTSBORO WATER, SEWER &amp; GAS BOARD</b></p> <p><b><i>SANITARY SEWER CONSTRUCTION STANDARD DETAILS</i></b></p> <p><b>404 E. WILLOW ST. SCOTTSBORO, AL 35768</b></p> <p><b>PHONE: (256) 574-1515 FAX: (256) 574-1965</b></p>	<b>SD-12</b>
	STANDARD SANITARY SEWER SERVICE CONNECTION
	APPROVED BY: R.E.L.
	DATE IMPLEMENTED: 7/21/09
	REVISIONS: 8/8/17

**NOTES**

1.) PVC PIPING SHALL BE 4" SCHEDULE 40 FROM THE MAIN TO THE CLEAN-OUT.

2.) CELL-CORE PIPE IS NOT ACCEPTABLE.

3.) ALL PIPING SHALL BE DUCTILE IRON CLASS 350 IN AREAS WITH LESS THAN 3- FEET OF COVER OR MORE THAN 12- FEET OF COVER.

4.) MECHANICAL JOINTS REQUIRED ON DUCTILE IRON PIPE.

5.) CONCRETE SHALL BE 3000 PSI.

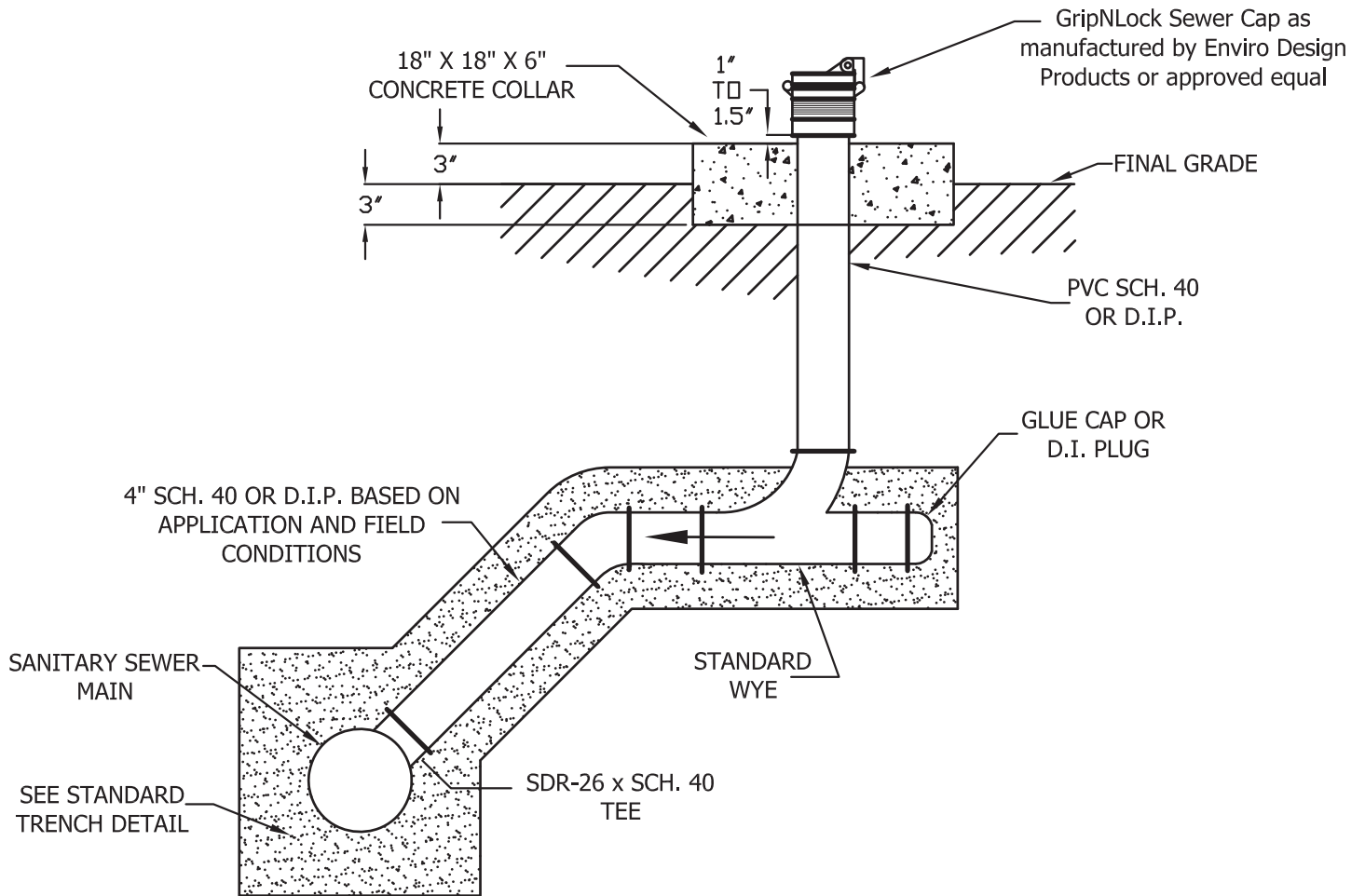
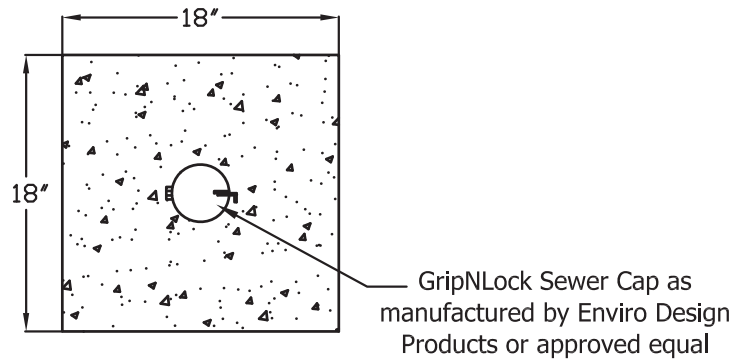

**SCOTTSBORO WATER, SEWER & GAS BOARD**

***SANITARY SEWER CONSTRUCTION STANDARD DETAILS***

**404 E. WILLOW ST.  
SCOTTSBORO, AL 35768**

**PHONE: (256) 574-1515  
FAX: (256) 574-1965**

**SD-12a**

**R.V. SANITARY SEWER SERVICE CONNECTION**

APPROVED BY: R.E.L.

DATE IMPLEMENTED: 11/04/11

REVISIONS: 6/25/13; 8/8/17

**NOTES**

- 1.) PVC PIPING SHALL BE 4" SCHEDULE 40 FROM THE MAIN TO THE CLEAN-OUT.
- 2.) CELL-CORE PIPE IS NOT ACCEPTABLE.
- 3.) ALL PIPING SHALL BE DUCTILE IRON CLASS 350 IN AREAS WITH LESS THAN 3-FEET OF COVER OR MORE THAN 12-FEET OF COVER.
- 4.) MECHANICAL JOINTS REQUIRED ON DUCTILE IRON PIPE.
- 5.) CONCRETE SHALL BE 3000 PSI.

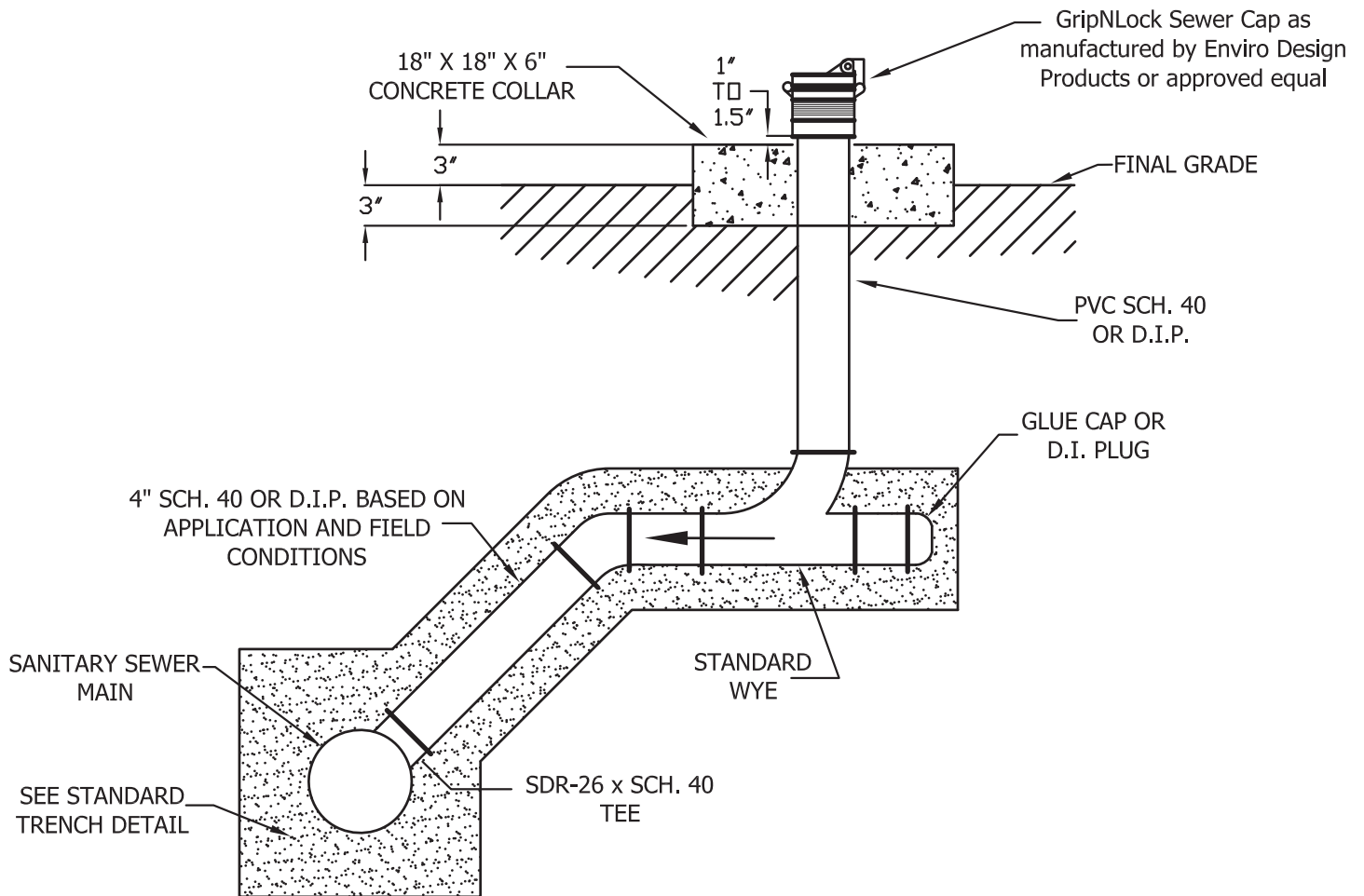
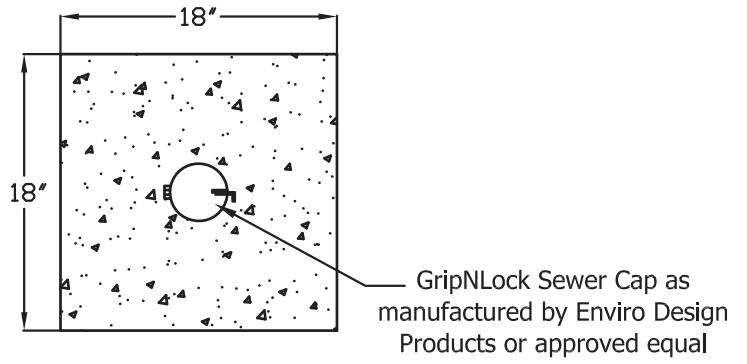

<p><b>SCOTTSBORO WATER, SEWER &amp; GAS BOARD</b></p> <p><b><i>SANITARY SEWER CONSTRUCTION STANDARD DETAILS</i></b></p> <p><b>404 E. WILLOW ST. SCOTTSBORO, AL 35768</b></p> <p><b>PHONE: (256) 574-1515 FAX: (256) 574-1965</b></p>	<p><b>SD-12b</b></p>
	<p>MOBILE HOME SANITARY SEWER SERVICE CONNECTION</p>
	<p>APPROVED BY: R.E.L.</p>
	<p>DATE IMPLEMENTED: 11/04/11</p>
	<p>REVISIONS: 06/25/13; 8/8/17</p>
	<p> </p>
	<p> </p>

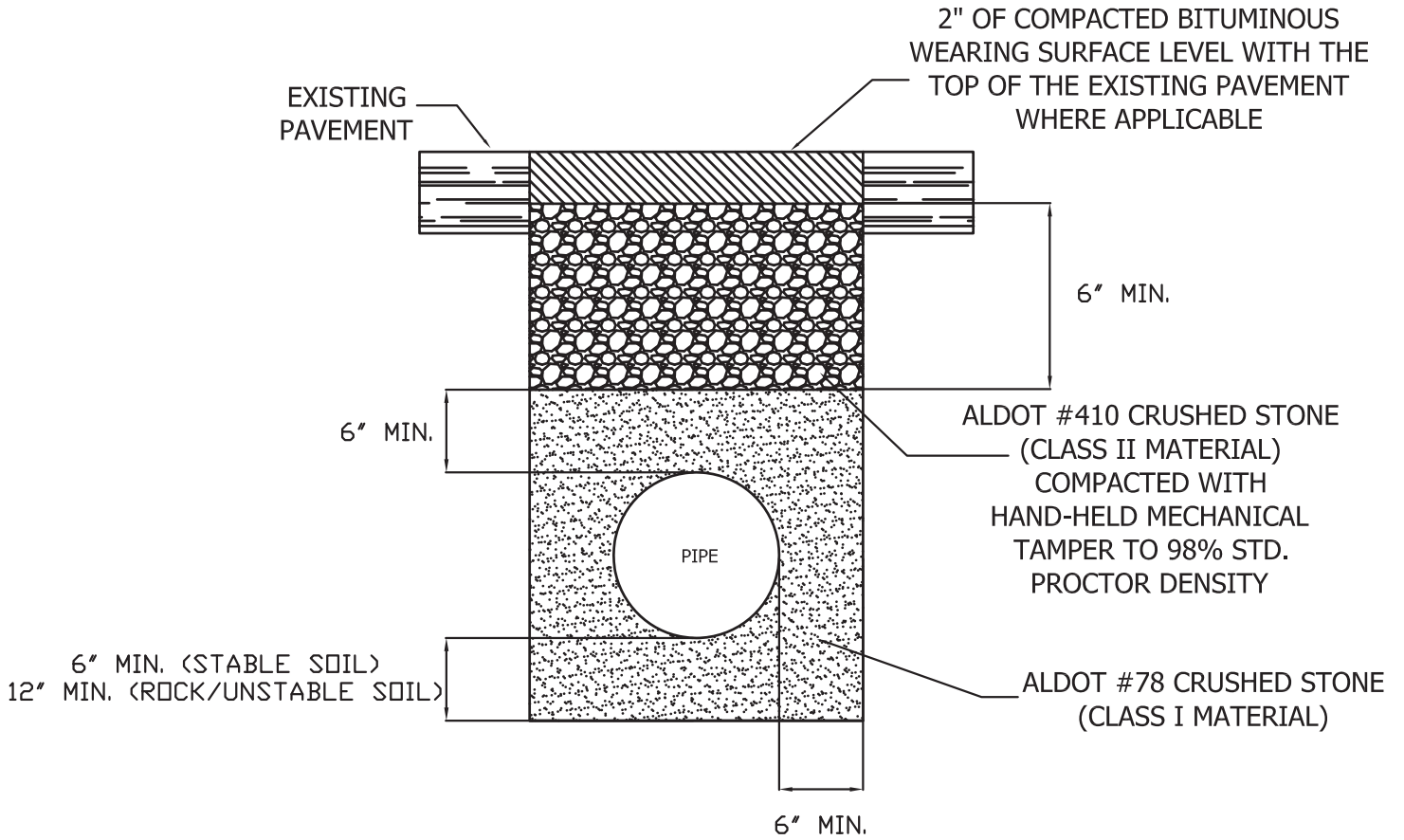

**NOTES**

- 1.) A CONTINUOUS STRIP OF GREEN, 12 GAUGE COPPER WIRE SHALL BE INSTALLED ONE FOOT ABOVE ALL LOW AND HIGH PRESSURE SANITARY SEWER FORCE MAINS

**SCOTTSBORO WATER, SEWER & GAS BOARD**

***SANITARY SEWER CONSTRUCTION STANDARD DETAILS***

**404 E. WILLOW ST.  
SCOTTSBORO, AL 35768**

**PHONE: (256) 574-1515  
FAX: (256) 574-1965**

**SD-13**

TYPICAL TRENCH FOR TRAFFIC AREAS

APPROVED BY: R.E.L.

DATE IMPLEMENTED: 7/21/09

REVISIONS: 9/16/09; 8/8/17

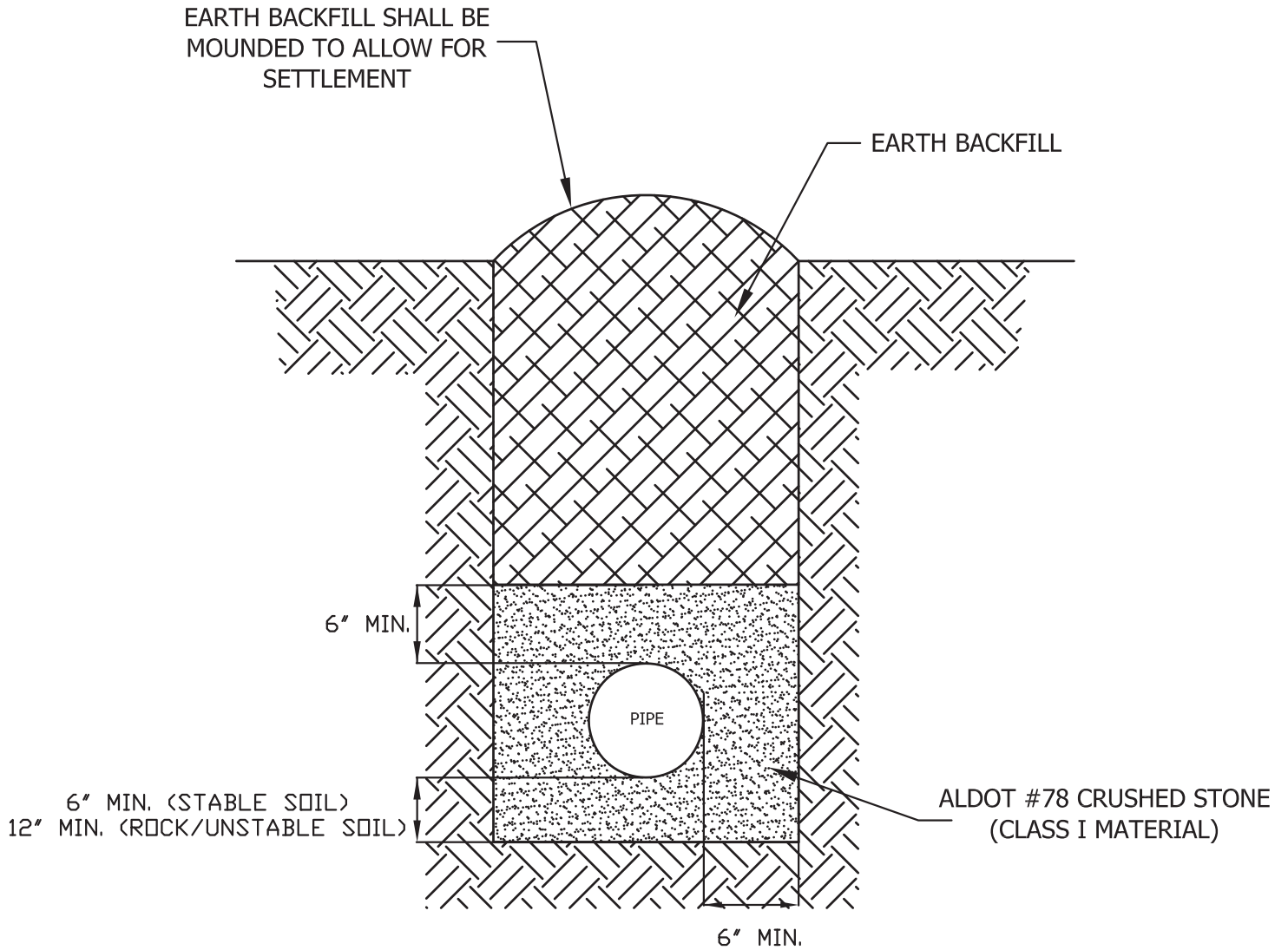

**NOTES**

- 1.) A CONTINUOUS STRIP OF GREEN, 12 GAUGE COPPER WIRE SHALL BE INSTALLED ONE FOOT ABOVE ALL LOW AND HIGH PRESSURE SANITARY SEWER FORCE MAINS

**SCOTTSBORO WATER, SEWER & GAS BOARD**

***SANITARY SEWER CONSTRUCTION  
STANDARD DETAILS***

**404 E. WILLOW ST.  
SCOTTSBORO, AL 35768**

**PHONE: (256) 574-1515  
FAX: (256) 574-1965**

**SD-13A**

TYPICAL TRENCH

APPROVED BY: R.E.L.

DATE IMPLEMENTED: 7/21/09

REVISIONS: 8/8/17

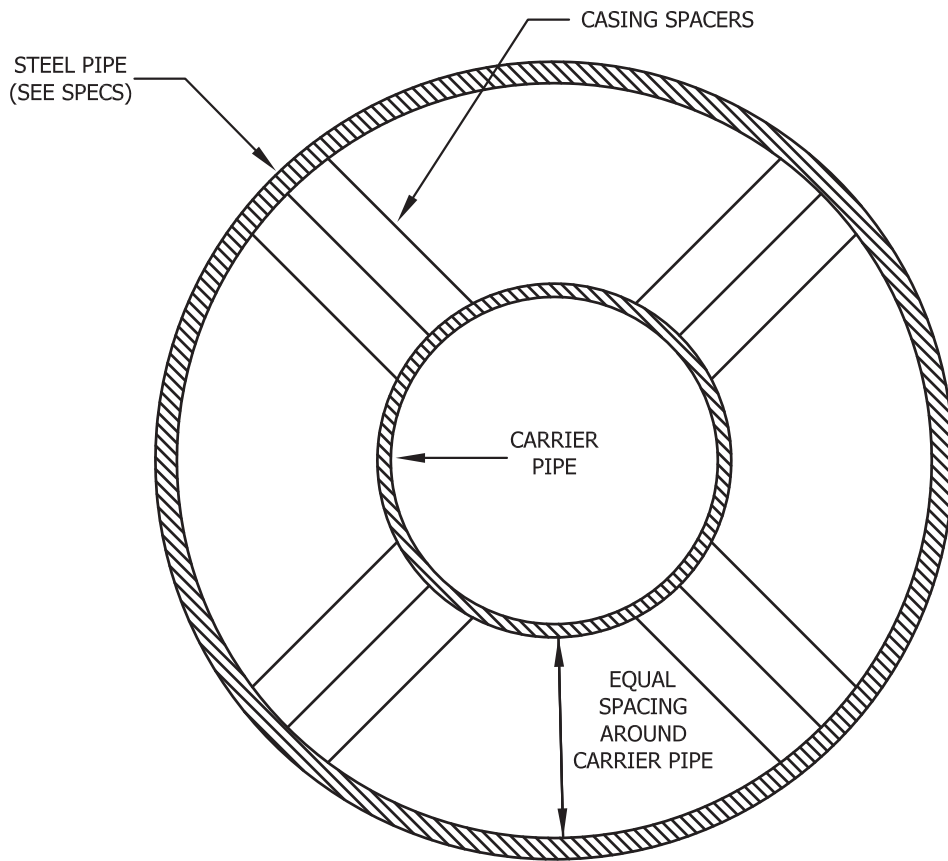

**NOTES**

1.) CASING SPACERS SHALL BE SPACED A MAXIMUM OF ONE FOOT FROM EACH SIDE OF JOINTS. THERE SHALL BE A MINIMUM OF 4 FEET AND A MAXIMUM OF 6 FEET BETWEEN SPACERS.

2.) MANUFACTURED SPACING SYSTEM SHALL BE APPROVED BY ENGINEER.

3.) CASING SHALL HAVE END SEALS WITH STAINLESS STEEL CLAMPS, 17 LB SACRIFICIAL ANODE (CERTIFIED PACKAGED MAGNESIUM H-1 ALLOY) GRADE 1 FALCON LINE PRODUCTS OR APPROVED EQUAL.

**SCOTTSBORO WATER, SEWER & GAS BOARD**

***SANITARY SEWER CONSTRUCTION STANDARD DETAILS***

**404 E. WILLOW ST.  
SCOTTSBORO, AL 35768**

**PHONE: (256) 574-1515  
FAX: (256) 574-1965**

**SD-14**

PIPE ENCASEMENT

APPROVED BY: R.E.L.

DATE IMPLEMENTED: 7/21/09

REVISIONS: 8/8/17



COMPACTED GRANULAR FILL  
PLACED BETWEEN CONCRETE  
AND UNDISTURBED EARTH

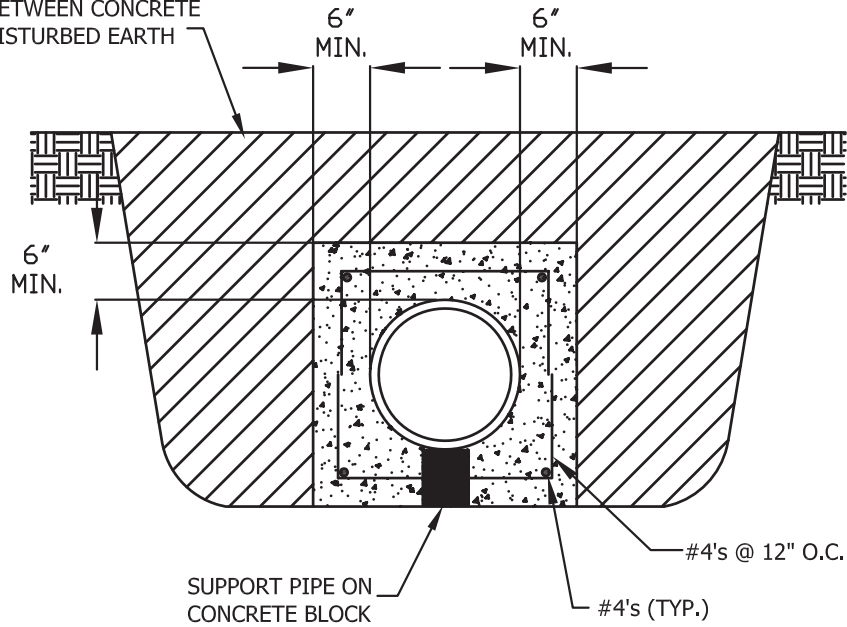

**NOTES**

1.) CONTROL JOINTS AND PIPE JOINTS FOR ENCASEMENT SHALL COINCIDE FOR SPACING. MAXIMUM DISTANCE BETWEEN CONTROL JOINTS SHALL BE 24 FEET.

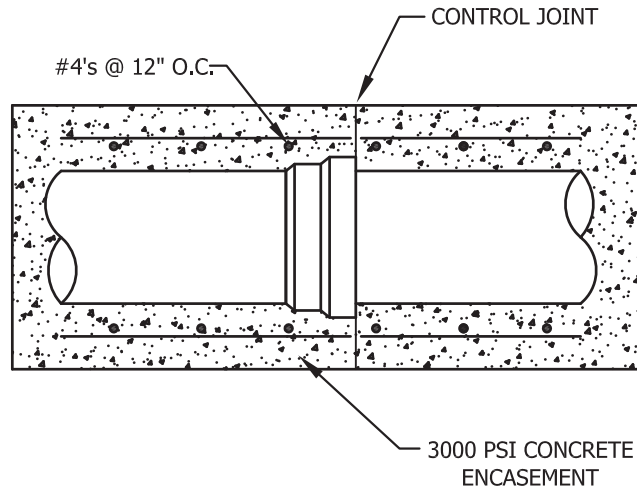

**SCOTTSBORO WATER, SEWER & GAS BOARD**

***SANITARY SEWER CONSTRUCTION  
STANDARD DETAILS***

**404 E. WILLOW ST.  
SCOTTSBORO, AL 35768**

**PHONE: (256) 574-1515  
FAX: (256) 574-1965**

**SD-15**

CREEK CROSSING  
CONCRETE ENCASEMENT WITH  
CONTROL JOINTS

APPROVED BY: R.E.L.

DATE IMPLEMENTED: 7/21/09

REVISIONS:

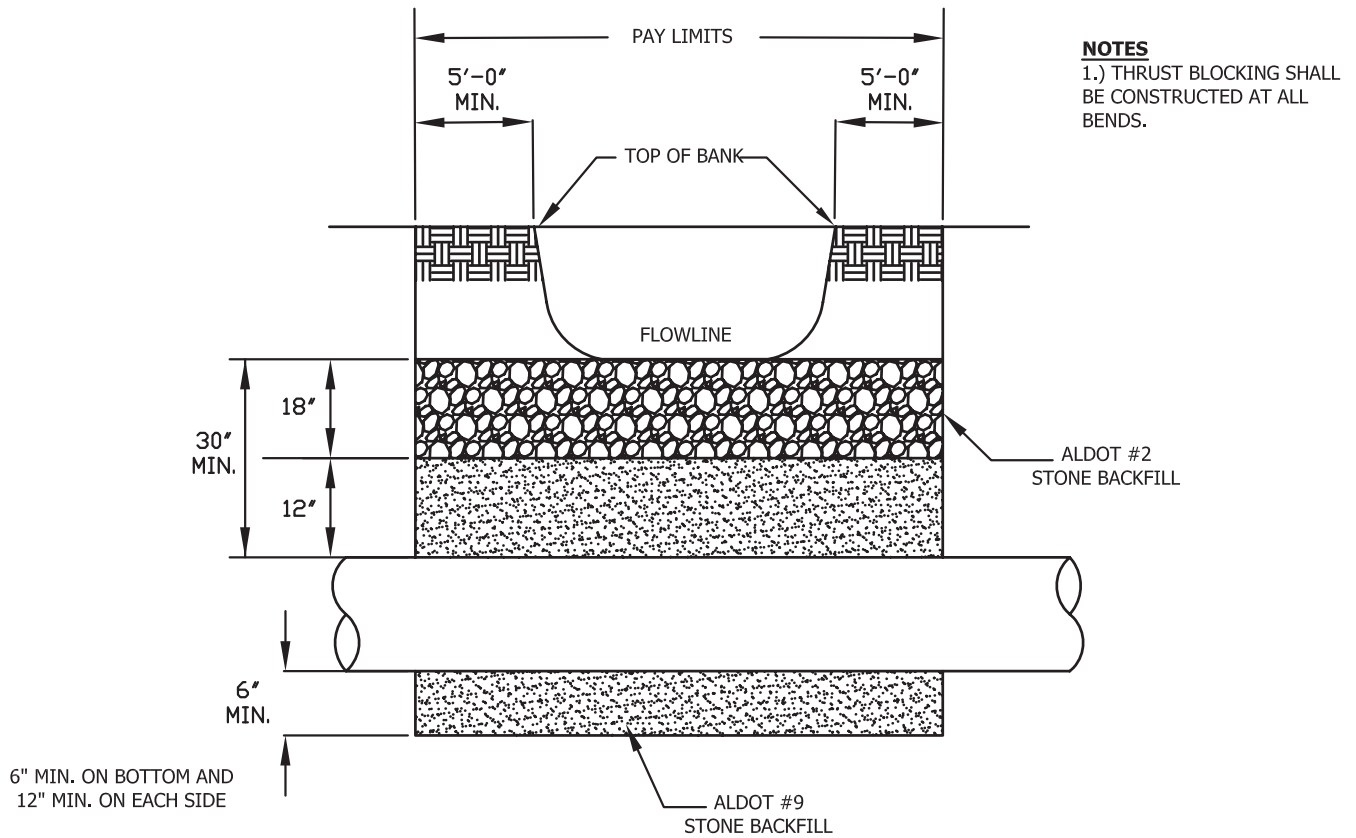



<p><b>SCOTTSBORO WATER, SEWER &amp; GAS BOARD</b></p> <p><b>SANITARY SEWER CONSTRUCTION STANDARD DETAILS</b></p> <p><b>404 E. WILLOW ST. SCOTTSBORO, AL 35768</b></p> <p><b>PHONE: (256) 574-1515 FAX: (256) 574-1965</b></p>	<h1>SD-16</h1>
	<p>CREEK CROSSING IN EARTH OR LOOSE STONE</p>
	<p>APPROVED BY: R.E.L.</p>
	<p>DATE IMPLEMENTED: 7/21/09</p>
	<p>REVISIONS:</p>

**NOTES**

1.) FOR 14" AND LARGER CARRIER PIPE, THREE STAINLESS STEEL CENTERING RESTRAINING SPACERS SHALL BE USED FOR EVERY JOINT OF PIPE WITH ONE SPACER BEING WITHIN 12 INCHES OF EACH SIDE OF THE JOINT.

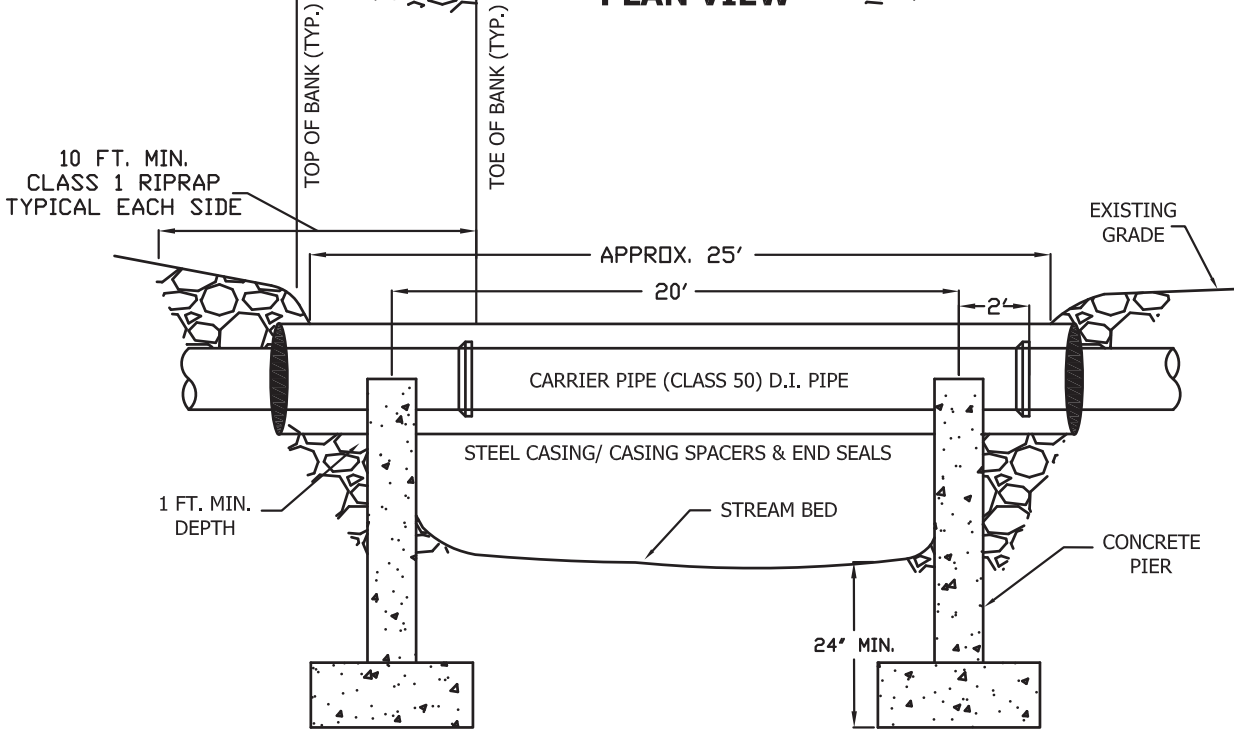
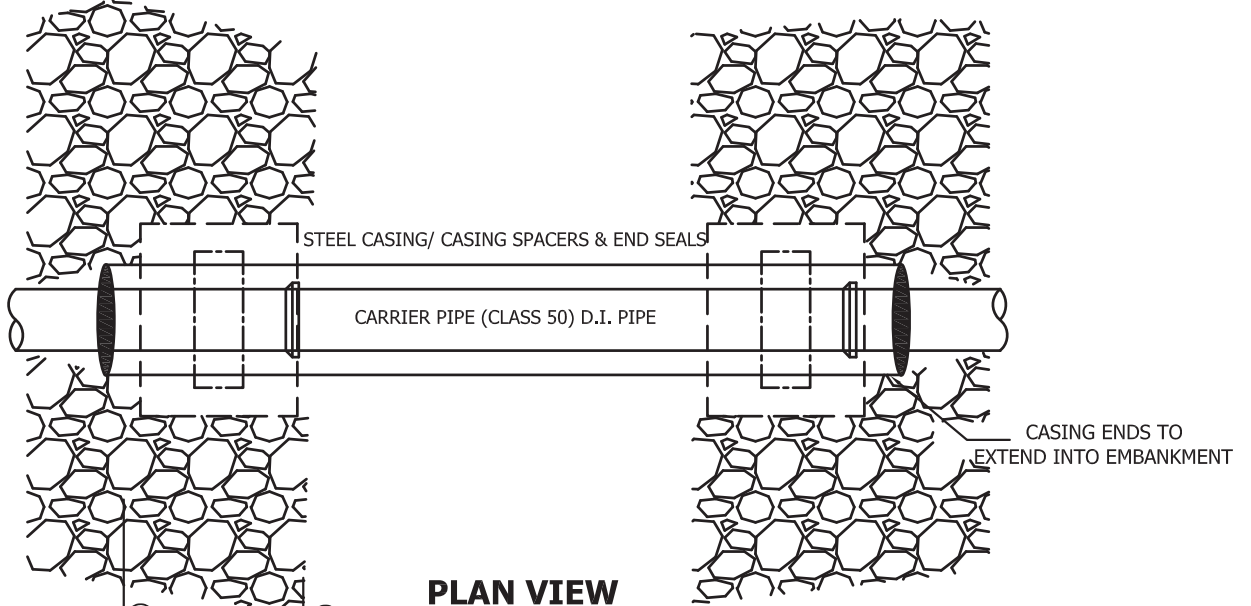
2.) FOR 12" AND SMALLER CARRIER PIPE, FOUR POLYETHYLENE CENTERING RESTRAINING SPACERS SHALL BE USED FOR EVERY JOINT OF PIPE WITH ONE SPACER BEING WITHIN 12 INCHES OF EACH SIDE OF THE JOINT.



<p><b>SCOTTSBORO WATER, SEWER &amp; GAS BOARD</b></p> <p><b>SANITARY SEWER CONSTRUCTION STANDARD DETAILS</b></p> <p><b>404 E. WILLOW ST. SCOTTSBORO, AL 35768</b></p> <p><b>PHONE: (256) 574-1515 FAX: (256) 574-1965</b></p>	<b>SD-17</b>
	ABOVE CREEK CROSSING
	APPROVED BY: R.E.L.
	DATE IMPLEMENTED: 7/21/09
	REVISIONS:

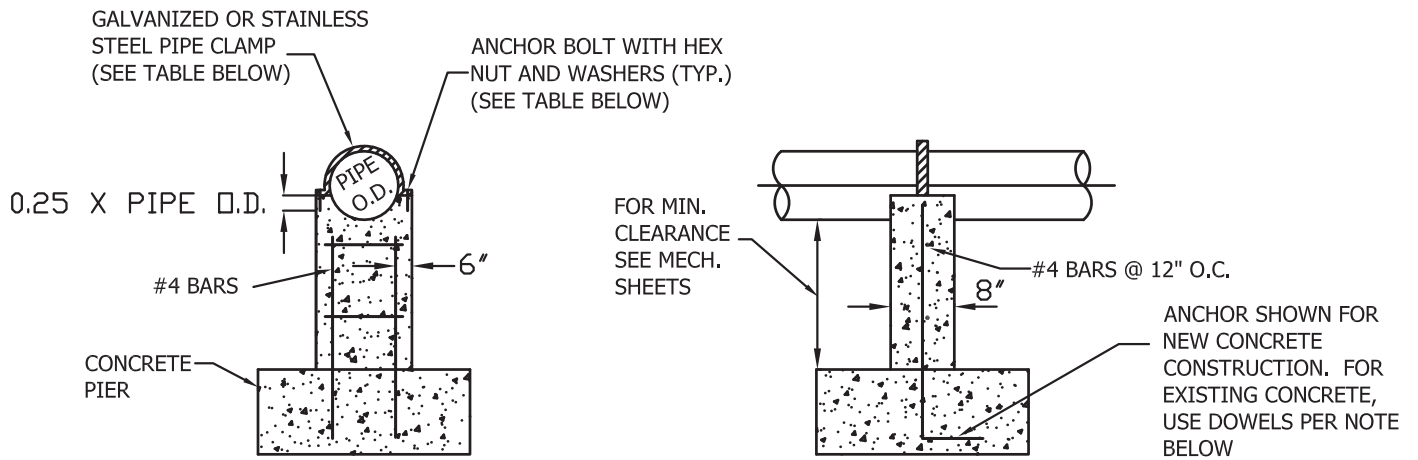

CONCRETE SADDLE TYPE PIPE SUPPORT

PIPE SIZE	MIN. SIZE CLAMP	MIN. SIZE ANCHOR BOLT
6"	1/8" x 1 1/2"	1/2"
8"	3/8" x 1 1/2"	5/8"
10"	3/8" x 2"	5/8"
12"	1/2" x 2"	5/8"
14"	1/2" x 2"	5/8"
16"	5/8" x 2 1/2"	3/4"

<p align="center"><b>SCOTTSBORO WATER, SEWER &amp; GAS BOARD</b></p> <p align="center"><b><i>SANITARY SEWER CONSTRUCTION STANDARD DETAILS</i></b></p> <p align="center"><b>404 E. WILLOW ST. SCOTTSBORO, AL 35768</b></p> <p align="center"><b>PHONE: (256) 574-1515 FAX: (256) 574-1965</b></p>	<h1>SD-18</h1>
	<p>ABOVE CREEK CROSSING SUPPORT</p>
	<p>APPROVED BY: R.E.L.</p>
	<p>DATE IMPLEMENTED: 7/21/09</p>
	<p>REVISIONS:</p>

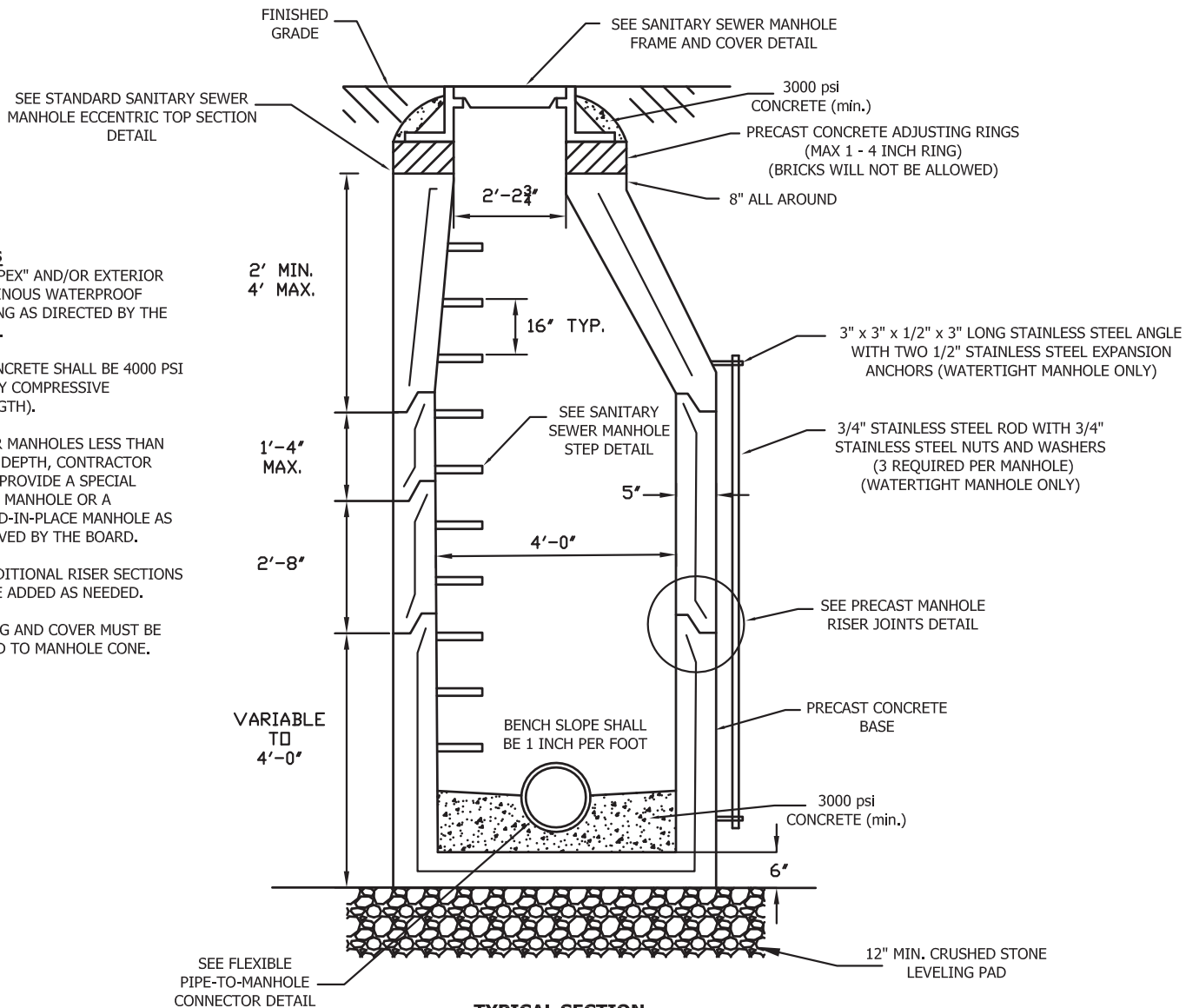

**NOTES**

- 1.) "XYPEX" AND/OR EXTERIOR BITUMINOUS WATERPROOF COATING AS DIRECTED BY THE BOARD.
- 2.) CONCRETE SHALL BE 4000 PSI (28-DAY COMPRESSIVE STRENGTH).
- 3.) FOR MANHOLES LESS THAN 4.5' IN DEPTH, CONTRACTOR SHALL PROVIDE A SPECIAL ORDER MANHOLE OR A POURED-IN-PLACE MANHOLE AS APPROVED BY THE BOARD.
- 4.) ADDITIONAL RISER SECTIONS MAY BE ADDED AS NEEDED.
- 5.) RING AND COVER MUST BE BOLTED TO MANHOLE CONE.

**TYPICAL SECTION**

(BASE SECTION FOR 6" TO 24" PIPE SHOWN)

<p><b>SCOTTSBORO WATER, SEWER &amp; GAS BOARD</b></p> <p><b>SANITARY SEWER CONSTRUCTION STANDARD DETAILS</b></p> <p><b>404 E. WILLOW ST. SCOTTSBORO, AL 35768</b></p> <p><b>PHONE: (256) 574-1515 FAX: (256) 574-1965</b></p>	<b>SD-19</b>
	SANITARY SEWER WATER-TIGHT MANHOLE
	APPROVED BY: R.E.L.
	DATE IMPLEMENTED: 7/21/09
	REVISIONS:

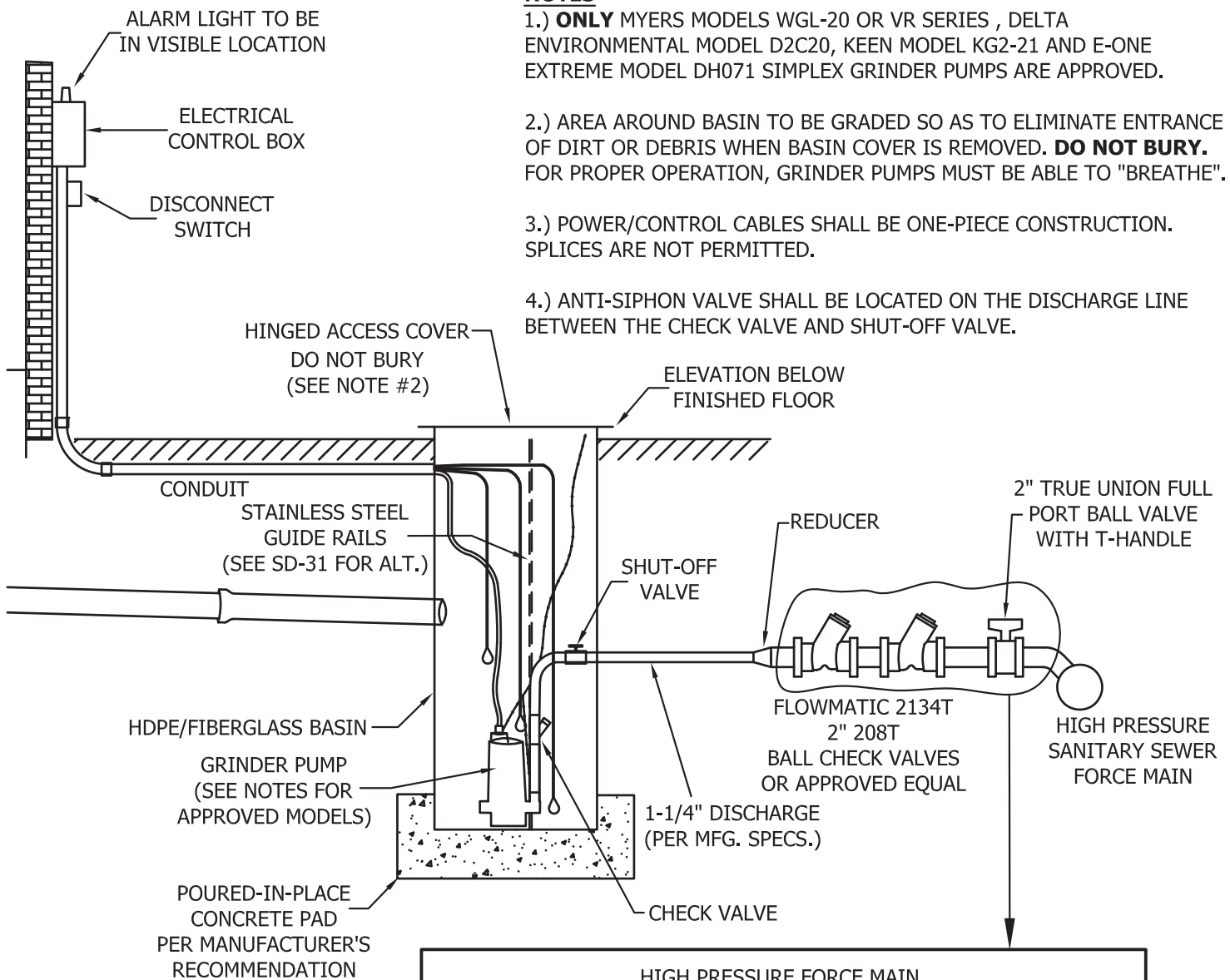

**NOTES**

- 1.) **ONLY** MYERS MODELS WGL-20 OR VR SERIES , DELTA ENVIRONMENTAL MODEL D2C20, KEEN MODEL KG2-21 AND E-ONE EXTREME MODEL DH071 SIMPLEX GRINDER PUMPS ARE APPROVED.
- 2.) AREA AROUND BASIN TO BE GRADED SO AS TO ELIMINATE ENTRANCE OF DIRT OR DEBRIS WHEN BASIN COVER IS REMOVED. **DO NOT BURY.** FOR PROPER OPERATION, GRINDER PUMPS MUST BE ABLE TO "BREATHE".
- 3.) POWER/CONTROL CABLES SHALL BE ONE-PIECE CONSTRUCTION. SPLICES ARE NOT PERMITTED.
- 4.) ANTI-SIPHON VALVE SHALL BE LOCATED ON THE DISCHARGE LINE BETWEEN THE CHECK VALVE AND SHUT-OFF VALVE.

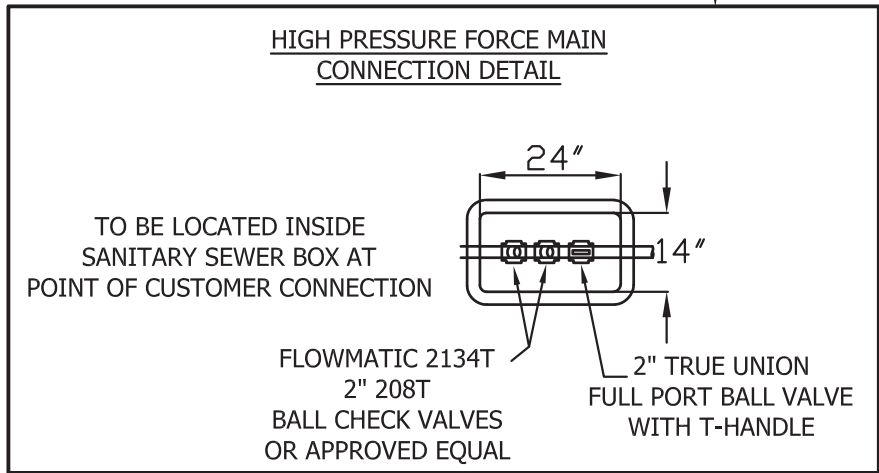

**SCOTTSBORO WATER, SEWER & GAS BOARD**

***SANITARY SEWER CONSTRUCTION STANDARD DETAILS***

**404 E. WILLOW ST.  
SCOTTSBORO, AL 35768**

**PHONE: (256) 574-1515  
FAX: (256) 574-1965**

**SD-20**

TYPICAL GRINDER PUMP INSTALLATION  
RESIDENTIAL CONNECTION TO HIGH  
PRESSURE SANITARY SEWER

APPROVED BY: R.E.L.

DATE IMPLEMENTED: 7/21/09

REVISIONS: 05/03/10-ADD KEEN MODEL  
6/25/13-REMOVE KEEN MODEL

04/22/15-ADD KEEN MODEL; 08/08/17

3/9/21-ADD ANTI-SIPHON VALVE NOTE

09/28/21-ADD MYERS VR SERIES MODEL

**NOTES**

- 1.) **ONLY** MYERS MODELS WGL-20 OR VR SERIES, DELTA ENVIRONMENTAL MODEL D2C20, KEEN MODEL KG2-21 AND E-ONE EXTREME MODEL DH071 SIMPLEX GRINDER PUMPS ARE APPROVED.
- 2.) AREA AROUND BASIN TO BE GRADED SO AS TO ELIMINATE ENTRANCE OF DIRT OR DEBRIS WHEN BASIN COVER IS REMOVED. **DO NOT BURY.** FOR PROPER OPERATION, GRINDER PUMPS MUST BE ABLE TO "BREATHE".
- 3.) POWER/CONTROL CABLES SHALL BE ONE-PIECE CONSTRUCTION. SPLICES ARE NOT PERMITTED.
- 4.) ANTI-SIPHON VALVE SHALL BE LOCATED ON THE DISCHARGE LINE BETWEEN THE CHECK VALVE AND SHUT-OFF VALVE.

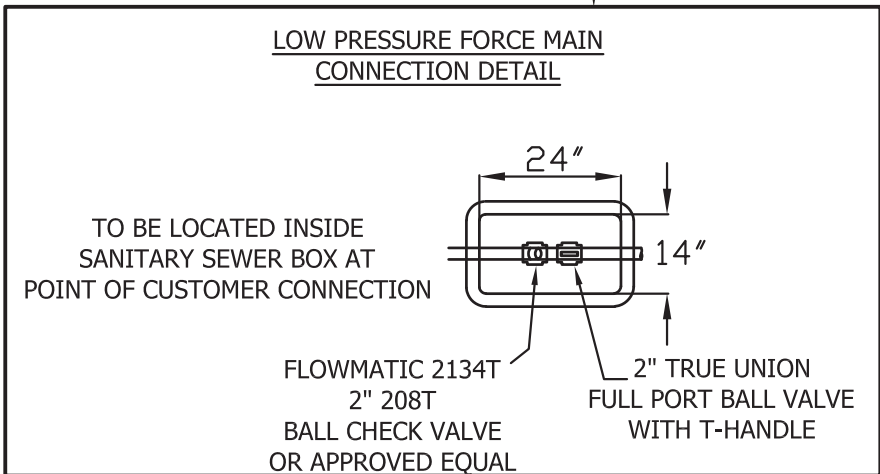
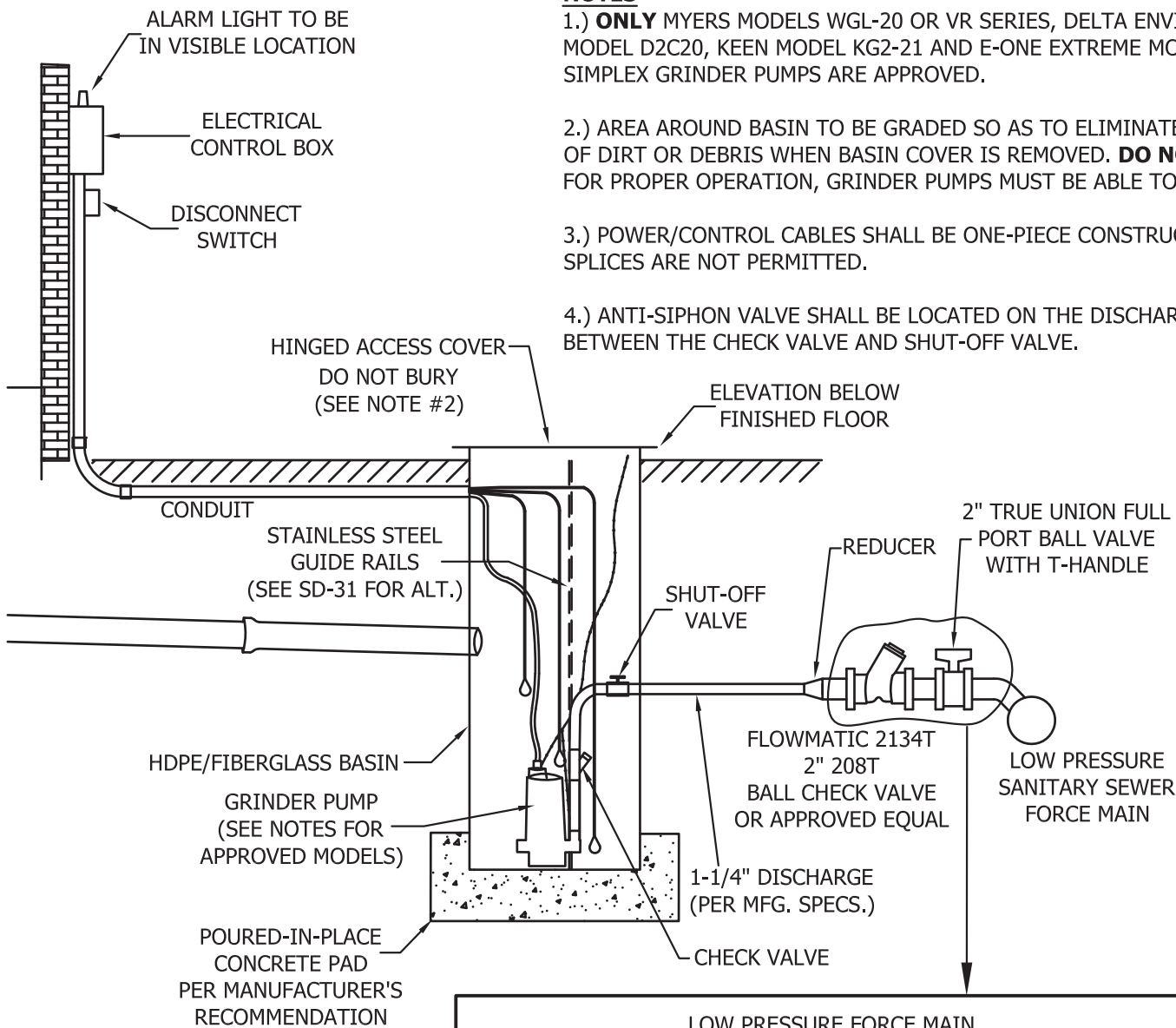

**SCOTTSBORO WATER, SEWER & GAS BOARD**

**SANITARY SEWER CONSTRUCTION STANDARD DETAILS**

**404 E. WILLOW ST.  
SCOTTSBORO, AL 35768**

**PHONE: (256) 574-1515  
FAX: (256) 574-1965**

**SD-21**

TYPICAL GRINDER PUMP INSTALLATION  
RESIDENTIAL CONNECTION TO LOW  
PRESSURE SANITARY SEWER

- APPROVED BY: R.E.L.
- DATE IMPLEMENTED: 7/21/09
- REVISIONS: 05/03/10-ADD KEEN MODEL
- 6/25/13-REMOVE KEEN MODEL
- 04/22/15-ADD KEEN MODEL; 08/08/17
- 3/9/21-ADD ANTI-SIPHON VALVE NOTE
- 09/28/21-ADD MYERS VR SERIES MODEL

**NOTES**

1.) **ONLY** MYERS MODELS WGL-20 OR VR SERIES, DELTA ENVIRONMENTAL MODEL D2C20, KEEN MODEL KG2-21 AND E-ONE EXTREME MODEL DH071 SIMPLEX GRINDER PUMPS ARE APPROVED.

2.) AREA AROUND BASIN TO BE GRADED SO AS TO ELIMINATE ENTRANCE OF DIRT OR DEBRIS WHEN BASIN COVER IS REMOVED. **DO NOT BURY.** FOR PROPER OPERATION, GRINDER PUMPS MUST BE ABLE TO "BREATHE".

3.) POWER/CONTROL CABLES SHALL BE ONE-PIECE CONSTRUCTION. SPLICES ARE NOT PERMITTED.

4.) ANTI-SIPHON VALVE SHALL BE LOCATED ON THE DISCHARGE LINE BETWEEN THE CHECK VALVE AND SHUT-OFF VALVE.

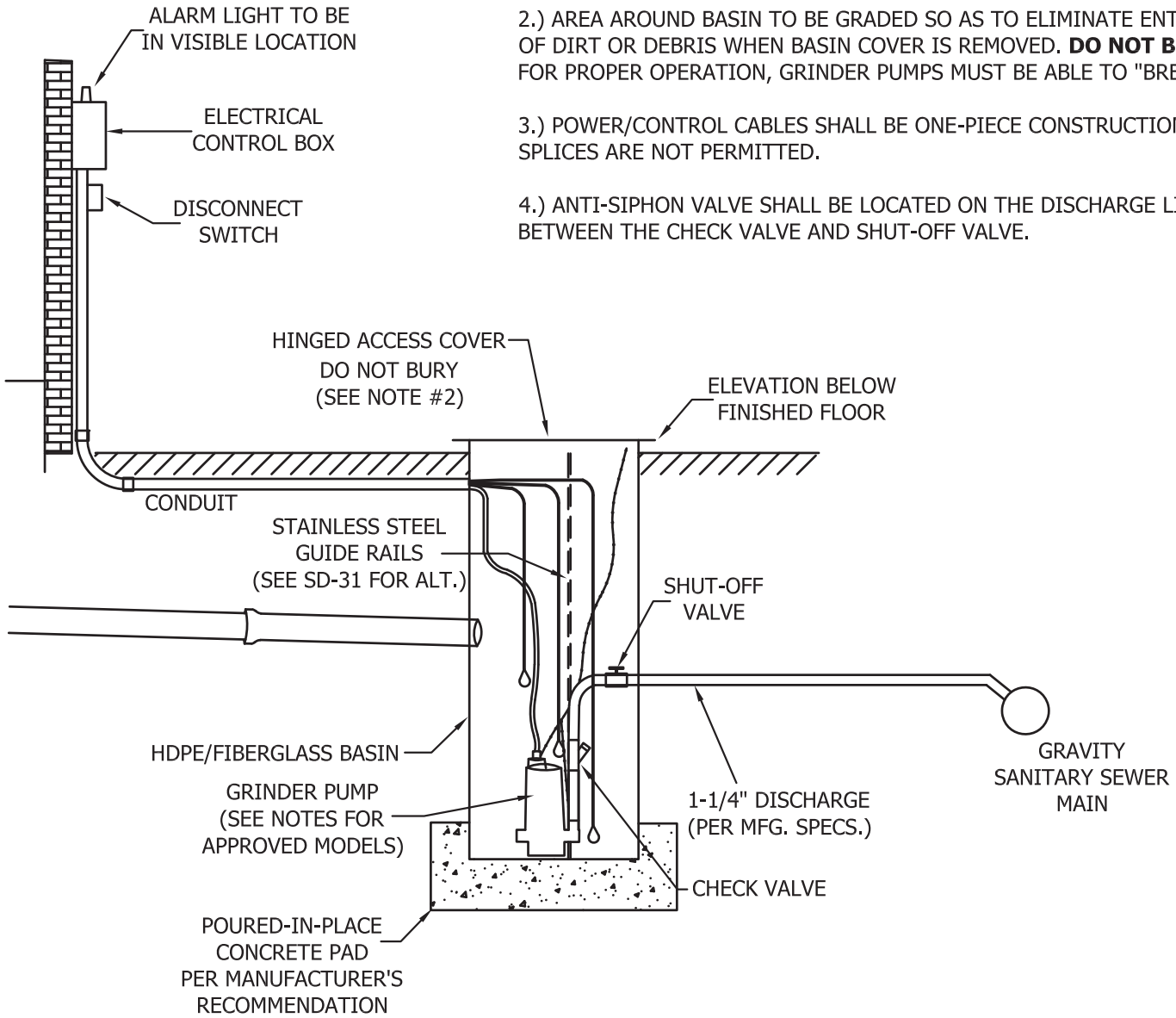

**SCOTTSBORO WATER, SEWER & GAS BOARD**

***SANITARY SEWER CONSTRUCTION STANDARD DETAILS***

**404 E. WILLOW ST.  
SCOTTSBORO, AL 35768**

**PHONE: (256) 574-1515  
FAX: (256) 574-1965**

**SD-22**

TYPICAL GRINDER PUMP INSTALLATION  
RESIDENTIAL CONNECTION TO GRAVITY  
SANITARY SEWER

APPROVED BY: R.E.L.

DATE IMPLEMENTED: 7/21/09

REVISIONS: 05/03/10-ADD KEEN MODEL

6/25/13-REMOVED KEEN MODEL

04/22/15-ADD KEEN MODEL

3/9/21-ADD ANTI-SIPHON VALVE NOTE

09/28/21-ADD MYERS VR SERIES MODEL



FIELD JOINT REQUIRED  
FOR MODELS  
DH071-129 & DH071-160

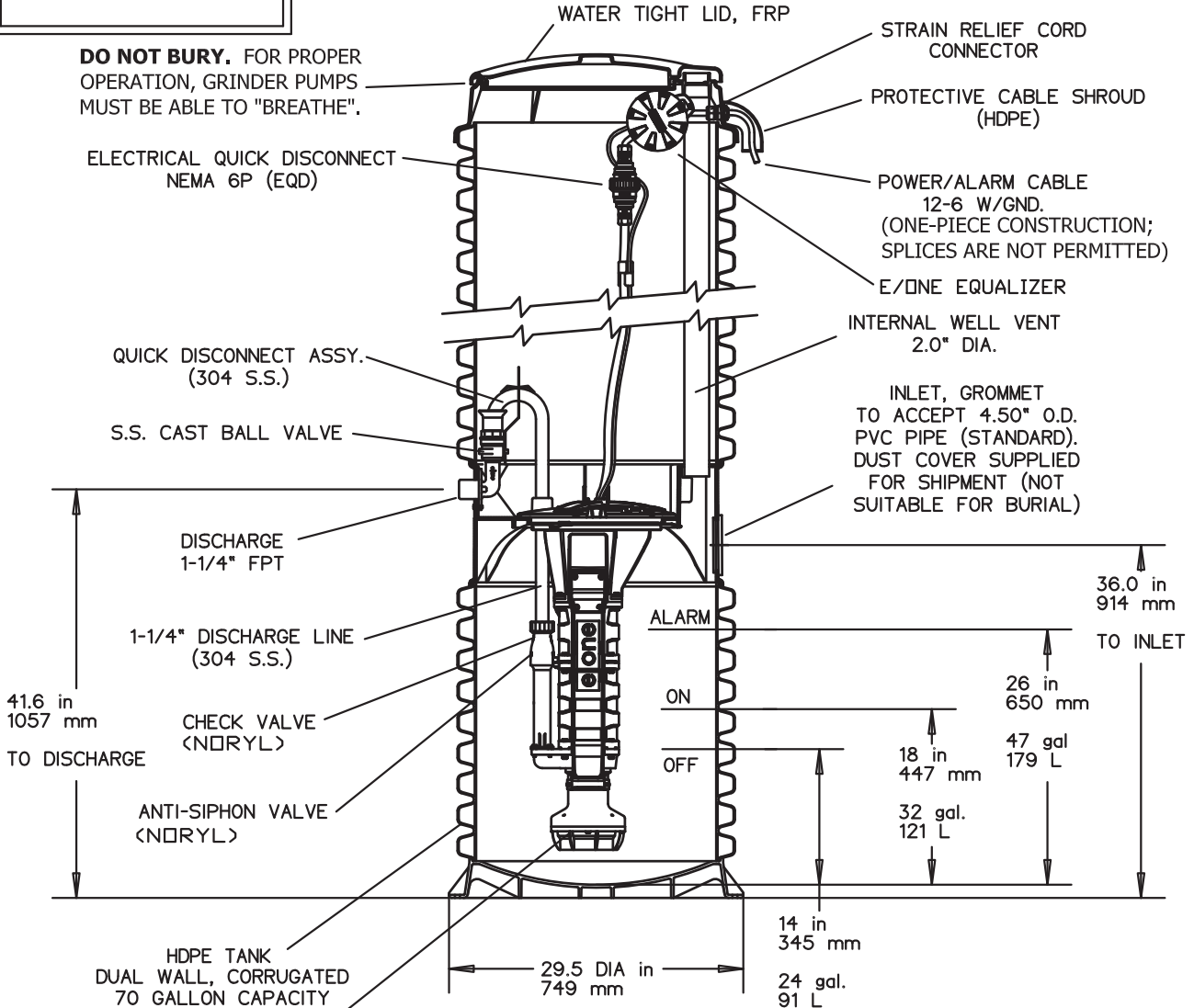

SEMI-POSITIVE DISPLACEMENT TYPE PUMP. EACH DIRECTLY DRIVEN BY A 1 HP MOTOR

BALLAST REQUIREMENTS

- 1.) A CONCRETE ANCHOR IS REQUIRED ON ALL OUTDOOR MODEL DH071 STATIONS.
- 2.) SPECIFIC CONCRETE DIMENSIONS ARE REQUIRED TO ACHIEVE NECESSARY BALLAST EFFECT.
- 3.) SEE INSTALLATION INSTRUCTIONS FOR FURTHER DETAILS/

<p><b>SCOTTSBORO WATER, SEWER &amp; GAS BOARD</b></p> <p><b>SANITARY SEWER CONSTRUCTION STANDARD DETAILS</b></p> <p><b>404 E. WILLOW ST. SCOTTSBORO, AL 35768</b></p> <p><b>PHONE: (256) 574-1515 FAX: (256) 574-1965</b></p>	<p><b>SD-23</b></p>
	<p>S.W.S.G. APPROVED E-ONE GRINDER PUMP MODEL DH071</p>
	<p>APPROVED BY: R.E.L.</p>
	<p>DATE IMPLEMENTED: 7/21/09</p>
	<p>REVISIONS:</p>
	<p> </p>

**STATOR**

2 hp, 3450 RPM, 1 and 3 phase. Press fit for perfect alignment and best heat transfer. Oil-filled motor conducts heat and lubricates bearings. Class F VFD/continuous duty rated.

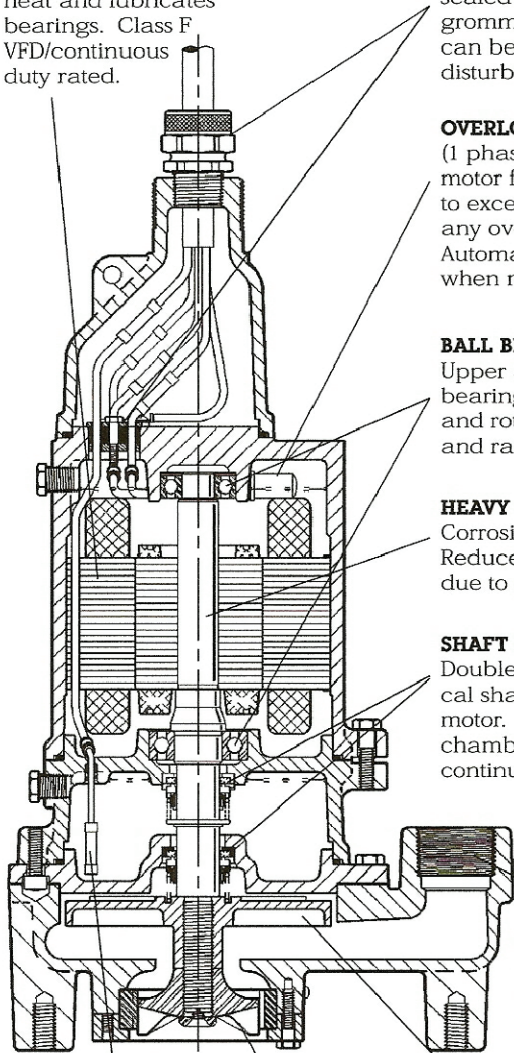

**CABLE ENTRY SYSTEM**

Provides double seal protection. Cable jacket sealed by compression fitting. Individual wires sealed by compression grommet. Power cord can be replaced without disturbing motor.

**OVERLOAD-HEAT SENSOR**

(1 phase only) Protects motor from burn-out due to excessive heat from any overload condition. Automatically resets when motor has cooled.

**BALL BEARINGS**

Upper and lower ball bearings support shaft and rotor and take axial and radial loads.

**HEAVY 416 SST SHAFT**

Corrosion resistant. Reduces shaft deflection due to grinding loads.

**SHAFT SEALS**

Double tandem mechanical shaft seals protect motor. Oil-filled seal chamber provides continuous lubrication.

**VOLUTE CASE**

Cast iron 1 1/4" NPT vertical flanged discharge.

**SEAL LEAK PROBE (Opt.)**

Detects water in seal housing, activates warning light in control panel.

**GRINDER ASSEMBLY**

Grinder impeller and shredding ring are replaceable without dismantling pump. Constructed of 440 SST hardened to 56-60 Rockwell.

**IMPELLER**

Cast iron recessed impeller handles ground slurry without clogging or binding. Provides unobstructed flow passage. Reduces radial loads. Pump-out vanes help keep trash from seal, reduces pressure at seal faces.



# WGL20 SERIES

**SCOTTSBORO WATER, SEWER & GAS BOARD**

**SANITARY SEWER CONSTRUCTION  
STANDARD DETAILS**

**404 E. WILLOW ST.  
SCOTTSBORO, AL 35768**

**PHONE: (256) 574-1515  
FAX: (256) 574-1965**

## SD-24

S.W.S.G. APPROVED  
MYERS GRINDER PUMP  
WGL20 SERIES

APPROVED BY: R.E.L.

DATE IMPLEMENTED: 7/21/09

REVISIONS:

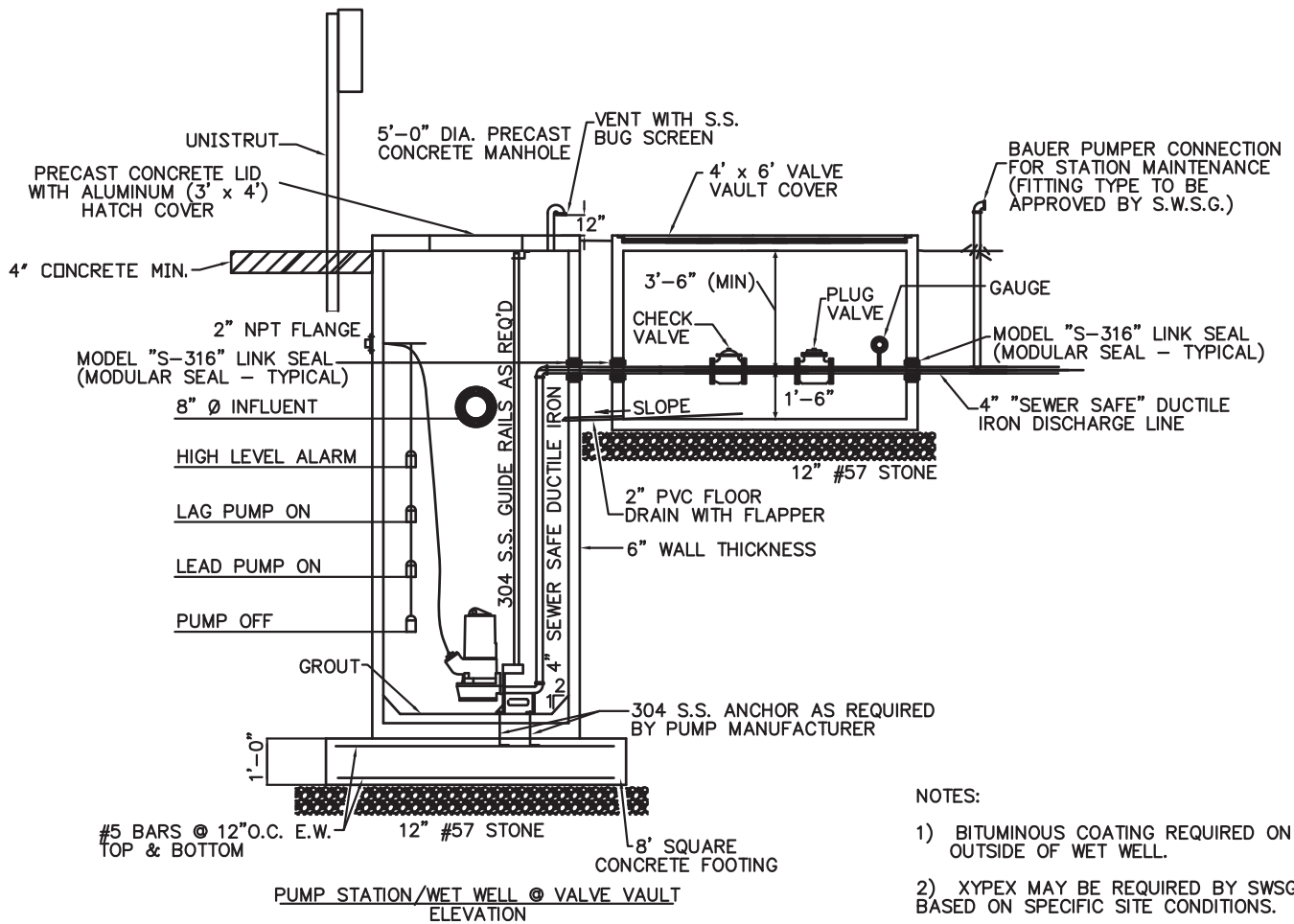
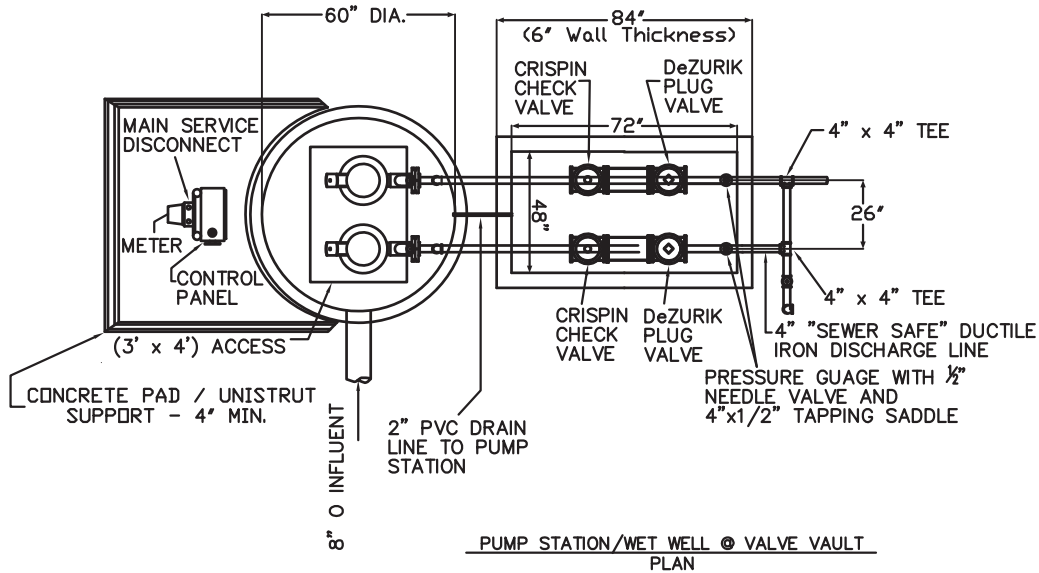
**NOTES:**

- 1) BITUMINOUS COATING REQUIRED ON OUTSIDE OF WET WELL.
- 2) XYPEX MAY BE REQUIRED BY SWSG BASED ON SPECIFIC SITE CONDITIONS.

**SCOTTSBORO WATER, SEWER & GAS BOARD**

***SANITARY SEWER CONSTRUCTION  
STANDARD DETAILS***

**404 E. WILLOW ST.  
SCOTTSBORO, AL 35768**

**PHONE: (256) 574-1515  
FAX: (256) 574-1965**

**SD-25**

**SANITARY SEWER PUMP STATION**

APPROVED BY: R.E.L.

DATE IMPLEMENTED: 7/21/09

REVISIONS:

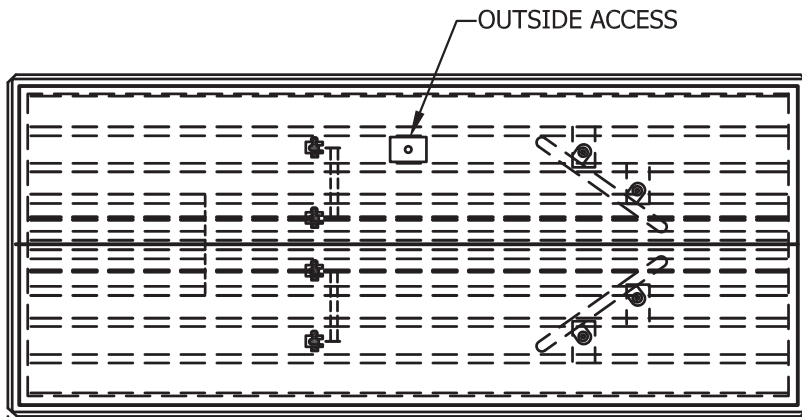
**PLAN**

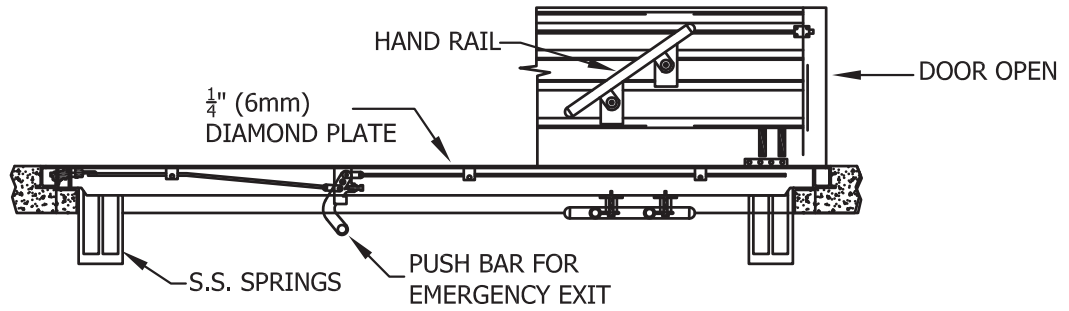

**PROFILE**



**EMERGENCY EXIT DOORS DESIGNED BY  
U.S.F. FABRICATION, INC.**

<p><b>SCOTTSBORO WATER, SEWER &amp; GAS BOARD</b></p> <p><b><i>SANITARY SEWER CONSTRUCTION STANDARD DETAILS</i></b></p> <p><b>404 E. WILLOW ST. SCOTTSBORO, AL 35768</b></p> <p><b>PHONE: (256) 574-1515 FAX: (256) 574-1965</b></p>	<p><b>SD-26</b></p>
	<p>SANITARY SEWER PUMP STATION HATCH DETAIL</p>
	<p>APPROVED BY: R.E.L.</p>
	<p>DATE IMPLEMENTED: 7/21/09</p>
	<p>REVISIONS:</p>

18" X 30" TALL VALVE ENCLOSURE WITH BOLT DOWN BASE AND REMOVABLE COVER. COVER AND BASE TO BE MANUFACTURED FROM  $\frac{3}{16}$ " THICK POLYETHYLENE WITH UV STABILIZERS. COVER TO BE PIPELINE PRODUCTS MODEL # VCAS-1830 OR APPROVED EQUAL.

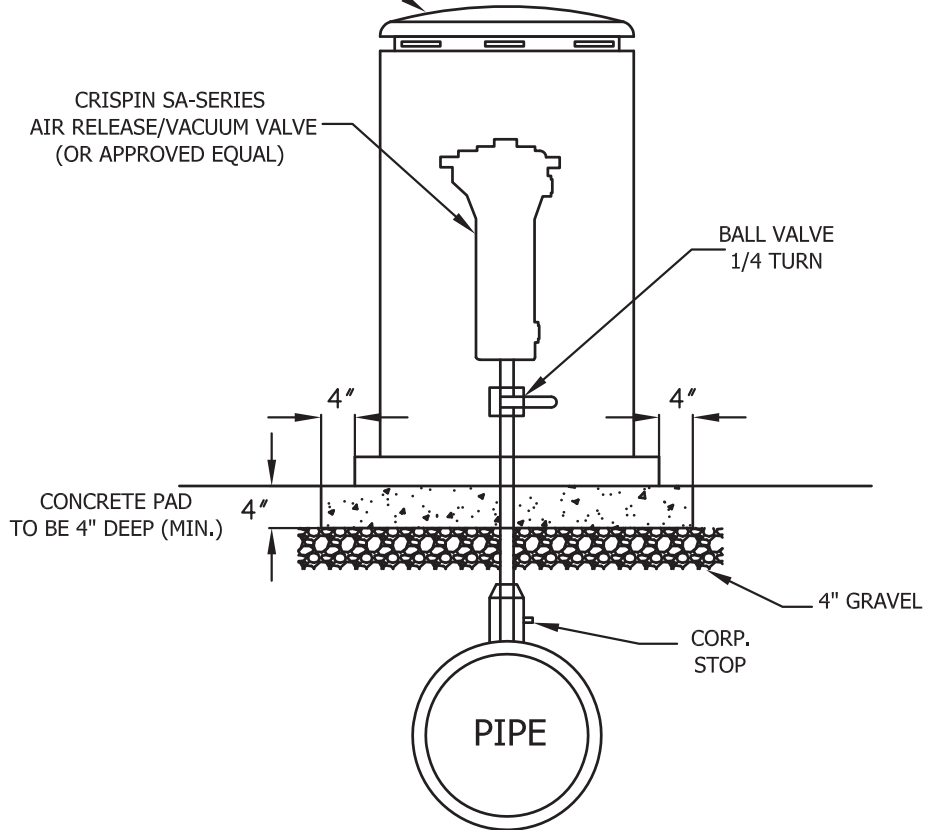

**ELEVATION**

<p><b>SCOTTSBORO WATER, SEWER &amp; GAS BOARD</b></p> <p><b><i>SANITARY SEWER CONSTRUCTION STANDARD DETAILS</i></b></p> <p><b>404 E. WILLOW ST. SCOTTSBORO, AL 35768</b></p> <p><b>PHONE: (256) 574-1515 FAX: (256) 574-1965</b></p>	<p><b>SD-27</b></p>
	<p>AIR/VACUUM VALVE ENCLOSURE</p>
	<p>APPROVED BY: R.E.L.</p>
	<p>DATE IMPLEMENTED: 7/21/09</p>
	<p>REVISIONS:</p>
	<p> </p> <p> </p> <p> </p>

**NOTES**

- 1.) 1,000 GALLON MINIMUM (SEE S-29 FOR SIZING FORMULA)
- 2.) SAND, OIL AND GREASE TRAP MUST COMPLY WITH ALABAMA CODE OF 1975 22-20-5.2, INCLUDING SADIE GRACE ANDREWS ACT EFFECTIVE JUNE 1, 2018.
- 3.) CERTIFICATION DEMONSTRATING COMPLIANCE WITH APPLICABLE STATE LAW IS REQUIRED.
- 4.) CONCRETE LID MUST BE TRAFFIC RATED (H-20 LOADING).
- 5.) CAST IRON MANHOLE RING AND COVER MUST BE TRAFFIC RATED (H-20 LOADING) AND SECURED OR LOCKED AT ALL TIMES.

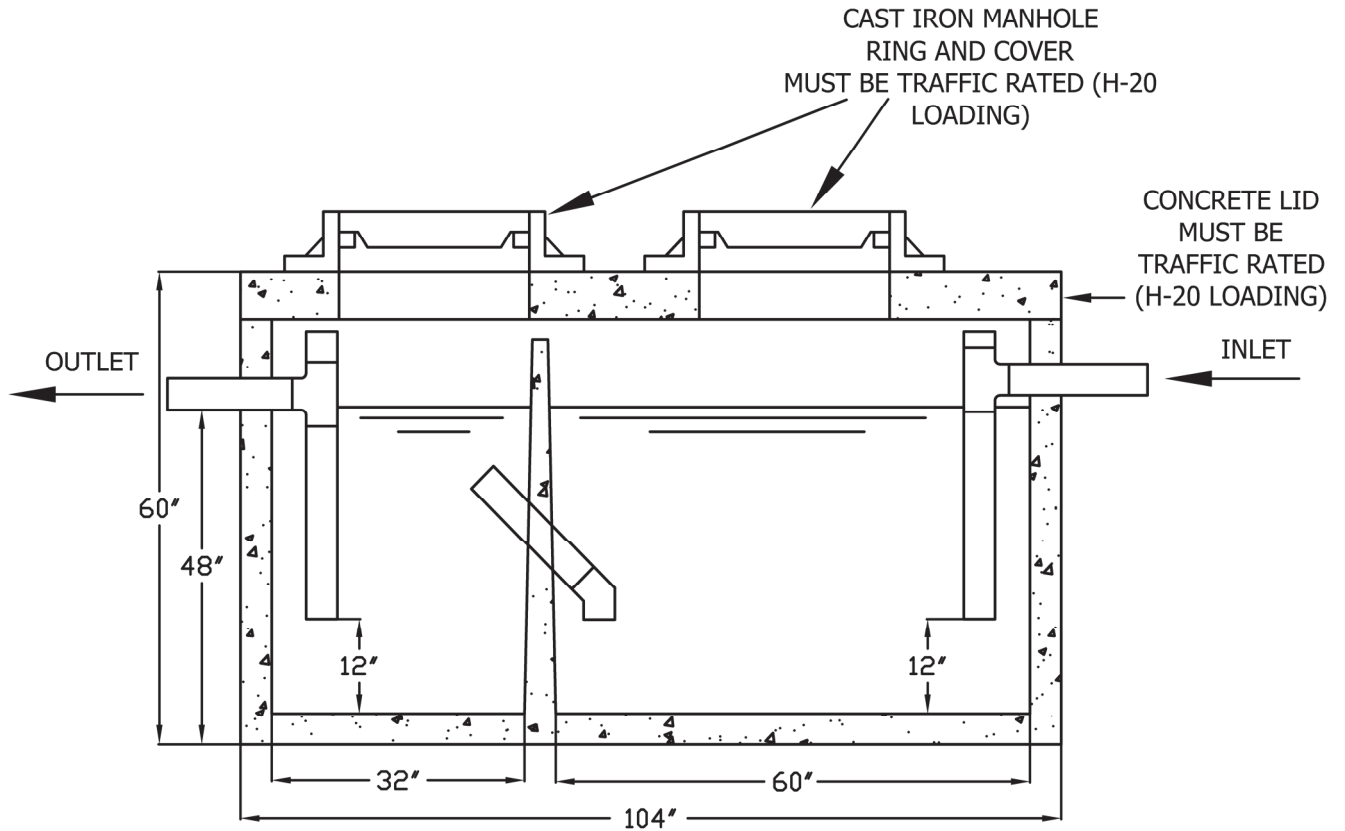

**SCOTTSBORO WATER, SEWER & GAS BOARD**

***SANITARY SEWER CONSTRUCTION STANDARD DETAILS***

**404 E. WILLOW ST.  
SCOTTSBORO, AL 35768**

**PHONE: (256) 574-1515  
FAX: (256) 574-1965**

**SD-28**

SAND, OIL & GREASE TRAP TYPICAL

APPROVED BY: R.E.L.

DATE IMPLEMENTED: 7/21/09

REVISIONS: 9/11/18 TRAFFIC RATED LIDS

## Sizing Formulas for Grease Control Equipment

### Formula: A x B x C x D x E = Grease Interceptor Size

Value Used	Code	Explanation
_____	(A)	Total Number of Seats
_____	(B)	Meal factor, based on establishment type and average time per meal
		1.33 Fast Food / Cafeteria ( 45 minutes)
		1.00 Restaurant ( 60 minutes)
		0.67 Leisure Dining ( 90 minutes)
_____	(C)	Gallons of wastewater per meal
		6.00 Full Commercial Kitchen with Dishwashing Machine
		5.00 Without Dishwashing Machine (Hand Washing of Plates/Utensils)
		2.00 Single Service Kitchen (Meals are served as take-out or on disposable plates/ utensils - Facility crockery is the only dish washing)
_____	(D)	Retention Time
		2.50 Commercial Kitchen
		1.50 Service Only Kitchen (No On-site Food Cooking - Prepared food served on disposal plates/utensils)
_____	(E)	Storage Factor, based on hours of operation
		1.00 Operation of 8 hours
		1.50 Operation of 12 hours
		2.00 Operation of 16 hours
		3.00 Operation of 24 Hours
		1.50 Service Only Kitchen (No On-site Food Cooking - Prepared food served on disposal plates/utensils)

\_\_\_\_\_ Estimated Size Needed **(Minimum Size shall be 1000 Gallons)**  
(Gallons)

(If there are no customer seats (carryout facility), use 25 for the number of seats. If the facility is a church, hospital, home school, or daycare, calculations will be 3 gallons per meal served at meal time.)

Facility Name: \_\_\_\_\_ Phone Number: \_\_\_\_\_

Address: \_\_\_\_\_ Contact Person: \_\_\_\_\_

This Worksheet Is Intended for Estimating Only.  
Scottsboro Waterworks, Sewer & Gas Board will make final Size Determination.

<b>SCOTTSBORO WATER, SEWER &amp; GAS BOARD</b>  <b><i>SANITARY SEWER CONSTRUCTION STANDARD DETAILS</i></b>  <b>404 E. WILLOW ST. SCOTTSBORO, AL 35768</b>  <b>PHONE: (256) 574-1515 FAX: (256) 574-1965</b>	<h1 style="margin: 0;">SD-29a</h1> <p style="margin: 0;">SAND, OIL &amp; GREASE TRAP SIZING FORMULA</p> <hr/> <p style="margin: 0;">APPROVED BY: R.E.L.</p> <p style="margin: 0;">DATE IMPLEMENTED: 7/21/09</p> <p style="margin: 0;">REVISIONS:</p> <hr/> <hr/> <hr/> <hr/>
---	--

**NOTES**

1.) REBAR SIZE #4 ON TOP AND BOTTOM ON 6" CENTERS/BIDIRECTIONAL. REBAR SIZE #4 ON SIDES 6" CENTERS AND LAPPED.

2.) 4,000 PSI CONCRETE

3.) TOP TO BE 6" THICK CONCRETE WITH MANHOLE RING AND COVER ATTACHED PER SWSG SPECS.

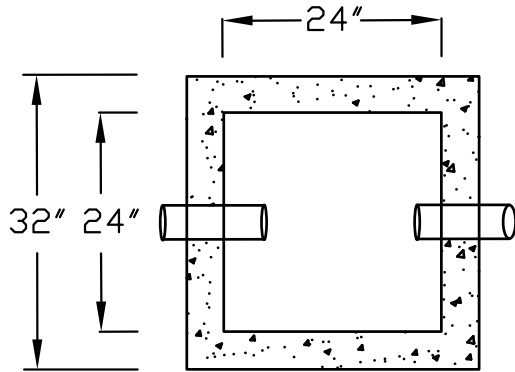

TOP VIEW

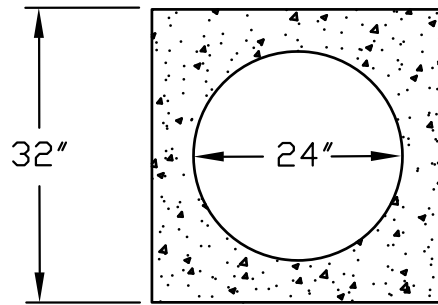

TOP (SEE NOTE 3)

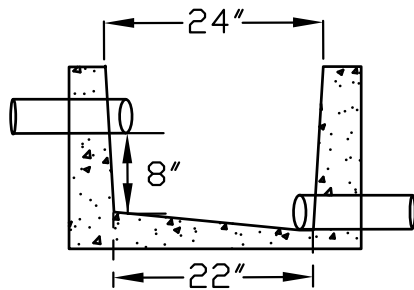

PROFILE VIEW

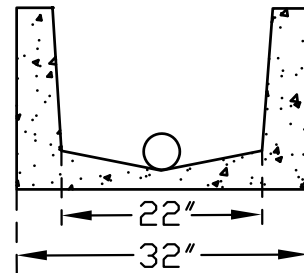

<p><b>SCOTTSBORO WATER, SEWER &amp; GAS BOARD</b></p> <p><b><i>SANITARY SEWER CONSTRUCTION STANDARD DETAILS</i></b></p> <p><b>404 E. WILLOW ST. SCOTTSBORO, AL 35768</b></p> <p><b>PHONE: (256) 574-1515 FAX: (256) 574-1965</b></p>	<p><b>SD-29b</b></p>
	<p>GREASE CONTROL SAMPLE BOX</p>
	<p>APPROVED BY: J.R.G.</p>
	<p>DATE IMPLEMENTED: 5/9/23</p>
	<p>REVISIONS:</p>



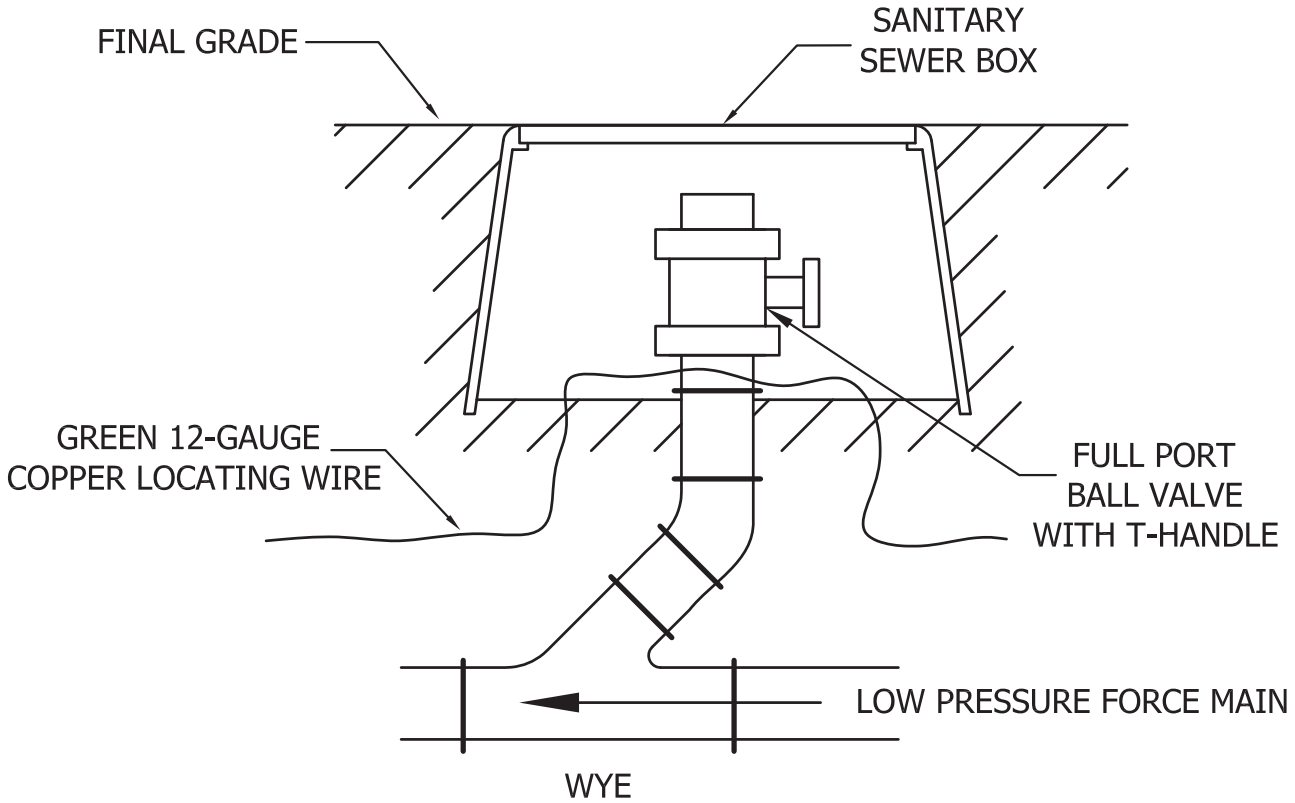

**SCOTTSBORO WATER, SEWER & GAS BOARD**

***SANITARY SEWER CONSTRUCTION  
STANDARD DETAILS***

**404 E. WILLOW ST.  
SCOTTSBORO, AL 35768**

**PHONE: (256) 574-1515  
FAX: (256) 574-1965**

**SD-30**

LOW PRESSURE FORCE MAIN  
CLEAN OUT

APPROVED BY: R.E.L.

DATE IMPLEMENTED: 7/21/09

REVISIONS: 8/8/17

**NOTES**

1.) PITLESS ADAPTER SETUP AS SHOWN MAY BE USED IN-LIEU OF GUIDE RAILS.

2.) BACKFLOW PREVENTER AND GATE VALVE MAY BE PLACED OUTSIDE OF CAN INSIDE A STANDARD SEWER VALVE BOX.

3.) SEE TYPICALS SD-20, SD-21 AND SD-22 FOR MORE DETAILS ON STATION REQUIREMENTS.

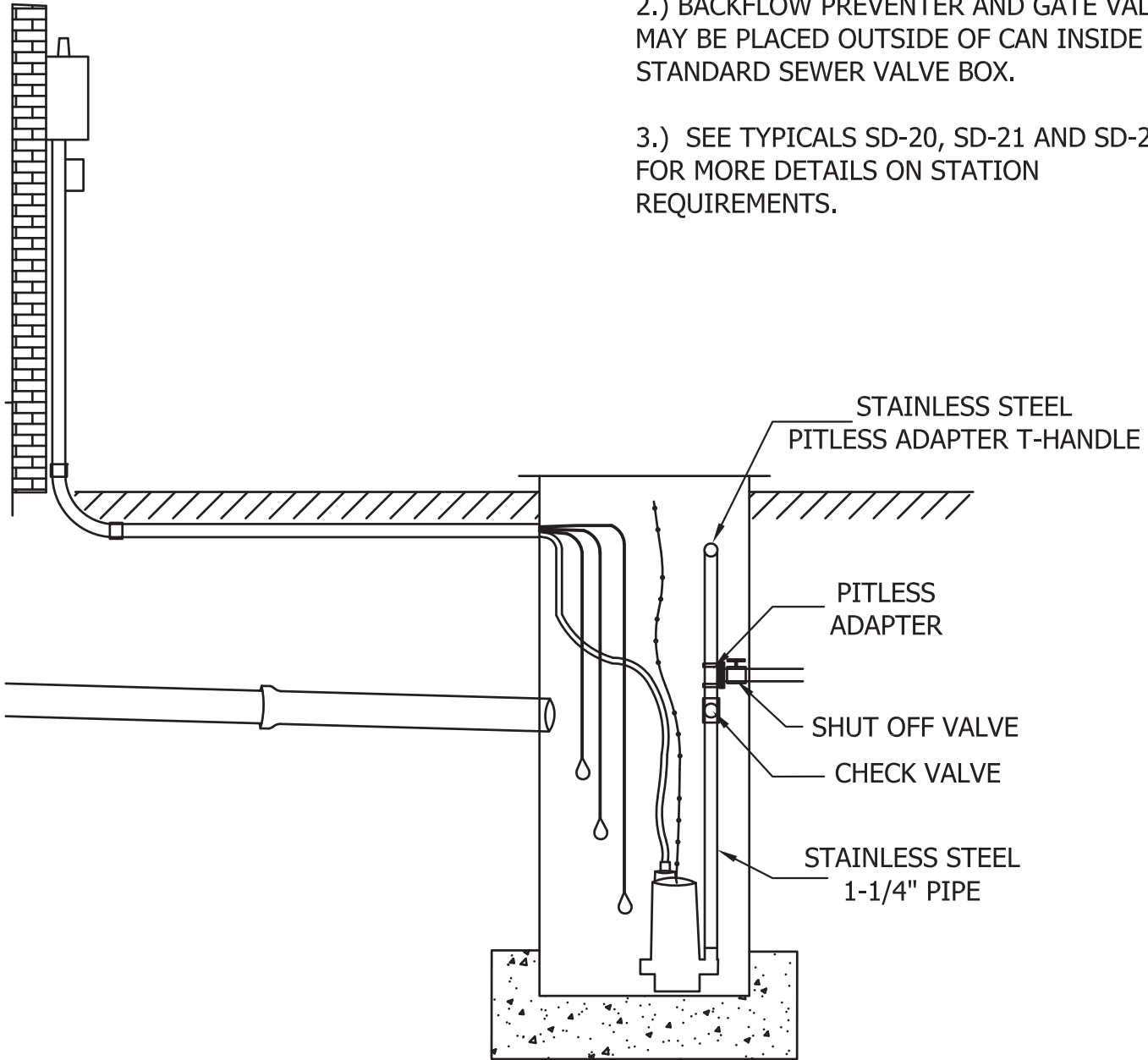

**SCOTTSBORO WATER, SEWER & GAS BOARD**

***SANITARY SEWER CONSTRUCTION STANDARD DETAILS***

**404 E. WILLOW ST.  
SCOTTSBORO, AL 35768**

**PHONE: (256) 574-1515  
FAX: (256) 574-1965**

**SD-31**

GRINDER PUMP PITLESS ADAPTER ALTERNATE

APPROVED BY: J.R.G.

DATE IMPLEMENTED: 9/28/21

REVISIONS:
